



PMX Series Powered Mixers

OPERATING MANUAL AND USER GUIDE



www.wharfedalepro.com

TABLE OF CONTENTS

1. Important Warnings & Safety Information	2
2. Introduction	4
3. About the PMX Series.....	4
4. PMX 500 Features:	5
5. PMX 700 Features:	5
6. PMX 710 Features:	5
7. PMX 500 Channels 1-4.....	6
8. PMX 500 Channel 5.....	6
9. PMX 500 Master section.....	7
10. PMX 500 Rear Panel	7
11. PMX 700 Channels 1-6.....	8
12. PMX 700 Channel 7	8
13. PMX 710 Channels 1-6.....	9
14. PMX 710 Channel 7	9
15. PMX 700 / PMX 710 Master Section.....	10
16. PMX 700 / PMX 710 Rear Panel.....	10
17. PMX500 Dimensional Drawings.....	11
18. PMX700 Dimensional Drawings.....	12
19. PMX710 Dimensional Drawings.....	13
20. PMX System Overview.....	14
21. Quick Start Guide	14
22. USB Interface	15
23. PMX500 Block Diagram	18
24. PMX700 Block Diagram	19
25. PMX710 Block Diagram	20
26. Specifications	21
27. Warranty	25



IMPORTANT WARNINGS & SAFETY INSTRUCTIONS

1. Read these instructions
2. Follow all instructions
3. Keep these instructions
4. Heed all warnings
5. Do not use this apparatus near water
6. Clean only with dry cloth.
7. Do not block any ventilation openings. Install in accordance with the manufacturer's instructions.
8. Do not install near any heat sources such as radiators, heat registers, stoves, or other apparatus (including amplifiers) that produce heat.
9. Do not defeat the safety purpose of a polarised or grounding plug. A polarised plug has two blades with one wider than the other. A grounding plug has two blades and a third grounding blade. The wide blade or the third blade is provided for your safety. If the provided plug does not fit into your outlet, consult an electrician for replacement of the obsolete outlet.
10. Protect the power cord from being walked on or pinched, particularly at the plug, receptacle and or the point where it exits from the apparatus.
11. Only use attachments/accessories specified by the manufacturer.
12. Only use a stand, tripod, bracket or rack specified by the manufacturer, or sold with the apparatus. When a rack is used, use caution when moving the rack and apparatus combination to avoid tip-over or injury.

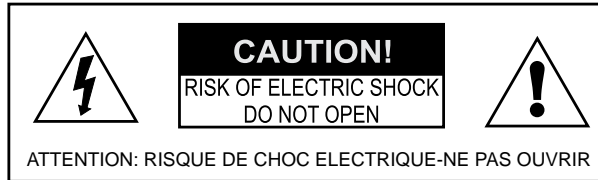

13. Unplug the apparatus during lightning storms or when unused for long periods of time.
14. Refer all servicing to qualified personnel. Servicing is required when the apparatus has been damaged in any way including but not limited to power supply cord or plug damage, liquid ingress, foreign objects in the chassis, exposure to rain/moisture or impact damage. In addition the unit must be serviced when you experience any abnormal operation.
15. **CAUTION:** These servicing instructions are for use by qualified service personnel only. To reduce the risk of electric shock, do not attempt to perform any servicing other than that contained in the operating instructions unless you are qualified to do so. In addition opening the casing will result in your warranty becoming null and void.
16. Do not install this apparatus in a confined space such as a book case or similar unit. Good ventilation should be maintained around the apparatus. Any vents, air-inlets or fans should not be obstructed by objects such as paper, table-cloths, curtains etc.
17. **WARNING:** To reduce the risk of fire or electric shock, do not expose the apparatus to rain or moisture. The apparatus should not be exposed to dripping or splashing and objects filled with liquids, such as vases, should not be placed on the apparatus.
18. **WARNING:** The mains plug/appliance coupler is used as a disconnect device, the disconnect device shall remain readily operable.



19. The lightning flash with arrowhead symbol within an equilateral triangle is intended to alert the user to the presence of non-insulated “dangerous voltage” within the product's enclosure that may be of sufficient magnitude to constitute a risk of electric shock.
- Warning: To reduce the risk of electric shock, do not remove the cover (or back) as there are no user-serviceable parts inside. Refer servicing to qualified personnel.
 - The exclamation point within an equilateral triangle is intended to alert the user to the presence of important operating and maintenance instructions in the literature accompanying the appliance.
20.  (Protective earthing terminal) The apparatus should be connected to a mains socket outlet with a protective earthing connection.
21.  Correct Disposal of this product. This marking indicates that this product should not be disposed with other household wastes throughout the EU. To prevent possible harm to the environment or human health from uncontrolled waste disposal, recycle it responsibly to promote the sustainable reuse of material resources. To return your used device, please use local return and collection systems or contact the retailer where the product was purchased. They can take this product for safe environmentally friendly recycling.

INTRODUCTION

Congratulations on the purchase of your PMX portable powered mixer. The Wharfedale Pro PMX Series is the result of many years experience in the use, design and manufacture of professional audio products. We take great pride in engineering and building every Wharfedale Pro product and wish to thank you for entrusting us with your sound.

From the time that Gilbert Briggs built his first loudspeaker in 1932, to the present day, Wharfedale have maintained the same standard of quality in components, workmanship and performance.

Please take the time to read this manual completely in order to ensure that you get the most from your PMX portable powered mixer.

ABOUT THE PMX SERIES

Designed to be a perfect balance of portability and power the PMX Series is suitable for use in a wide range of portable sound applications. Everything you need to mix and amplify microphones and line level sources is included in one box, with an ergonomic carry handle to aid transportation.

The one box concept speeds up your setup time and allows you to start your performance quicker than ever before.

All models feature built in digital FX processing, expanding your creativity and improving your sound quality without the need for additional expensive and often cumbersome processors. A graphic EQ allows fine tuning of the overall mix.

PMX 500 FEATURES:

- **150W RMS power output (4Ω)**
- **4 phantom powered XLR mic inputs**
- **¼" jack and RCA line level inputs**
- **Peak indicator for each channel**
- **2 band EQ on every channel**
- **Built in digital FX**
- **7 band Graphic EQ**
- **4 segment LED metering**
- **¼" jack/Speakon™ main outputs**

PMX 700 FEATURES:

- **2x 150W RMS power output (4Ω)**
- **6 phantom powered XLR mic inputs**
- **¼" jack and RCA line level inputs**
- **Peak indicator for each channel**
- **3 band EQ on every mono channel**
- **2 band EQ on the stereo channel**
- **1 Monitor send**
- **Built in digital FX**
- **Dual 7 band Graphic EQ**
- **4 segment LED metering**
- **¼" jack/Speakon™ main outputs**

PMX 710 FEATURES:

- **2x 250W RMS power output (4Ω)**
- **16-bit 48kHz USB interface**
- **6 phantom powered XLR mic inputs**
- **¼" jack and RCA line level inputs**
- **Peak indicator for each channel**
- **3 band EQ on every mono channel**
- **2 band EQ on the stereo channel**
- **1 Monitor send**
- **Pan/Balance controls**
- **Built in digital FX**
- **Dual 7 band Graphic EQ**
- **4 segment LED metering**
- **¼" jack/Speakon™ main outputs**

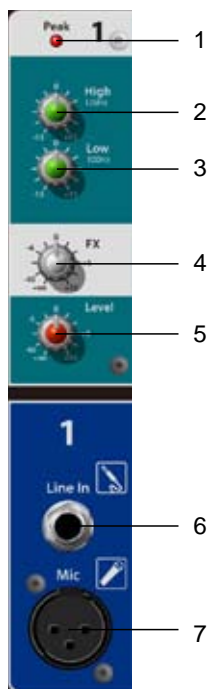

PMX 500 CHANNELS 1-4

1. Peak LED - Illuminates when the channel is clipping
2. High - High frequency shelving EQ, centered around 12kHz
3. Low - Low frequency shelving EQ, centered around 100Hz
4. FX Send - Sends signal to the built-in FX processor
5. Level - Controls the overall volume of the channel
6. Line in - Balanced / unbalanced ¼" TRS input for line level sources
7. Mic - Balanced XLR microphone input with switchable +48v phantom powering (Global Phantom power switch on rear of PMX unit)

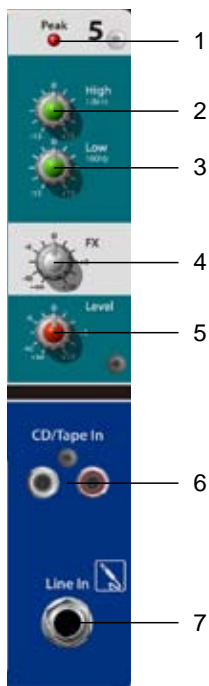

PMX 500 CHANNEL 5

1. Peak LED - Illuminates when the channel is clipping
2. High - High frequency shelving EQ, centered around 12kHz
3. Low - Low frequency shelving EQ, centered around 100Hz
4. FX Send - Sends signal to the built-in FX processor
5. Level - Controls the overall volume of the channel
6. CD/Tape In - Dual phono inputs for connection of consumer level stereo sources, the input will be summed to mono
7. Line in - Balanced / unbalanced ¼" TRS input for line level sources

PMX 500 MASTER SECTION

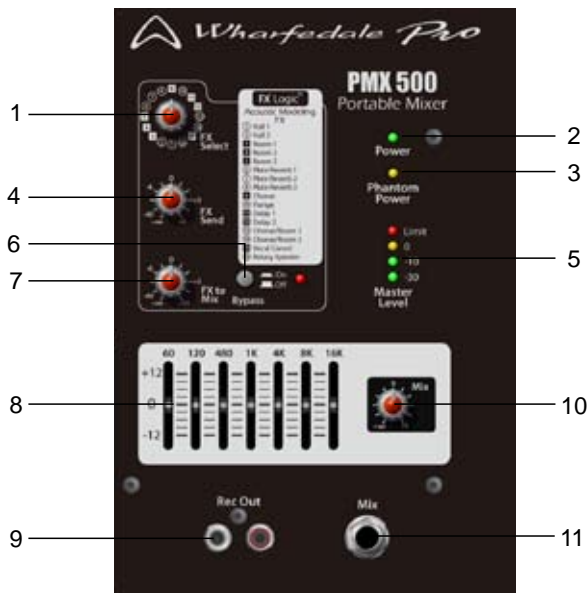

1. FX Select - Selects the effect type that will be used
2. Power LED - Indicates AC supply
3. Phantom Power LED - Indicates +48v phantom powering is supplied to all of the XLR inputs. Please check that all connected microphones can withstand +48v power input
4. FX Send - Allows for master adjustment of the FX send buss
5. Master Level LED's - 4 segment LED metering for the master buss, if the limit LED illuminates constantly lower the master level to avoid damage to your loudspeakers
6. Bypass - Used to switch the internal FX processor on or off

7. FX to Mix - Controls the output level of the internal FX processor to the master buss
8. 7-band EQ - Master section EQ to fine tune the overall sound
9. Rec Out - Line level output using phono connectors, provides connection to recording devices
10. Mix Level - Controls the main master volume
11. Mix output - Balanced / unbalanced 1/4" TRS master output

PMX 500 REAR PANEL

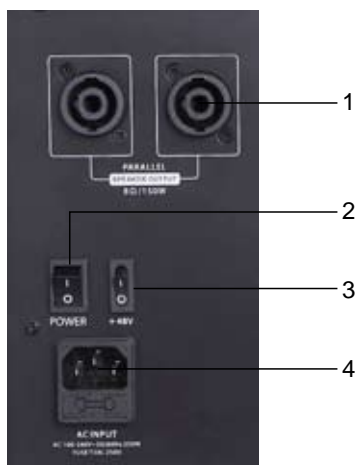

1. Speakon™ outputs - Parallel outputs for connection to your loudspeakers
PLEASE MAKE SURE THAT THE TOTAL IMPEDANCE OF THE LOAD IS NOT LESS THAN 4 OHMS.
2. Power Switch - Turns the unit on or off, ensure that AC is supplied and that the levels have been turned down to protect your speakers
3. Phantom Power switch - Activates the +48v phantom powering for the 4 XLR inputs
4. IEC receptacle - Allows input of the supplied IEC lead for AC supply

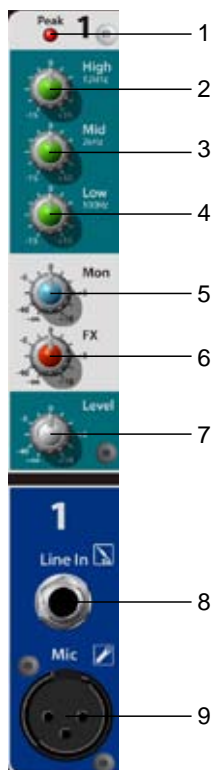

PMX 700 CHANNELS 1-6

1. Peak LED - Illuminates when the channel is clipping
2. High - High frequency shelving EQ, centered around 12kHz
3. Mid - Mid frequency shelving EQ, centered around 2kHz
4. Low - Low frequency shelving EQ, centered around 100Hz
5. Mon - Sends signal to a stage monitor
6. FX Send - Sends signal to the built-in FX processor
7. Level - Controls the overall volume of the channel
8. Line in - Balanced / unbalanced 1/4" TRS input for line level sources
9. Mic - Balanced XLR microphone input with switchable +48v phantom powering (Global Phantom power switch on rear of PMX unit)

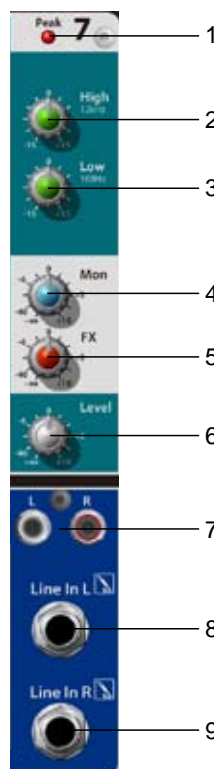

PMX 700 CHANNEL 7

1. Peak LED - Illuminates when the channel is clipping
2. High - High frequency shelving EQ, centered around 12kHz
3. Low - Low frequency shelving EQ, centered around 100Hz
4. Mon - Sends signal to a stage monitor
5. FX Send - Sends signal to the built-in FX processor
6. Level - Controls the overall volume of the channel
7. CD/Tape In - Dual phono inputs for connection of consumer level stereo sources
8. Line in L - Balanced / unbalanced 1/4" TRS input for left channel of line level sources
9. Line in R - Balanced / unbalanced 1/4" TRS input for right channel of line level sources

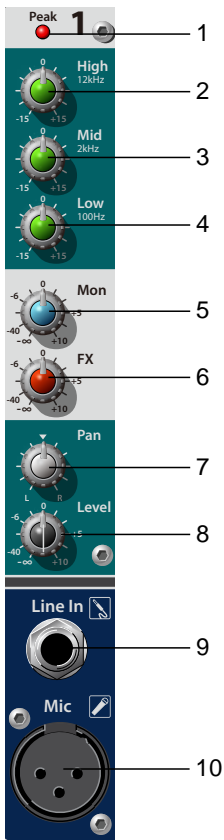

PMX 710 CHANNELS 1-6

1. Peak LED - Illuminates when the channel is clipping
2. High - High frequency shelving EQ, centered around 12kHz
3. Mid - Mid frequency shelving EQ, centered around 2kHz
4. Low - Low frequency shelving EQ, centered around 100Hz
5. Mon - Sends signal to a stage monitor
6. FX Send - Sends signal to the built-in FX processor
7. Pan - Places the signal within the stereo field
8. Level - Controls the overall volume of the channel
9. Line in - Balanced / unbalanced ¼" TRS input for line level sources
10. Mic - Balanced XLR microphone input with switchable +48v phantom powering (Global Phantom power switch on rear of PMX unit)

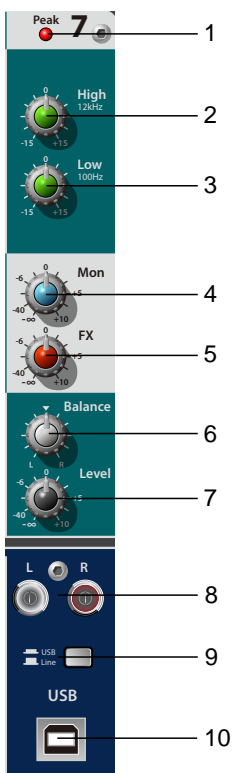

PMX 710 CHANNEL 7

1. Peak LED - Illuminates when the channel is clipping
2. High - High frequency shelving EQ, centered around 12kHz
3. Low - Low frequency shelving EQ, centered around 100Hz
4. Mon - Sends signal to a stage monitor
5. FX Send - Sends signal to the built-in FX processor
6. Balance - Spatially places the signal within the stereo field
7. Level - Controls the overall volume of the channel
8. CD/Tape In - Dual phono inputs for connection of consumer level stereo sources
9. USB/Line Switch - Selects the input source for the channel
10. USB Input - For connecting a computer, the PMX710 acts as an audio interface

PMX 700 / PMX 710 MASTER SECTION

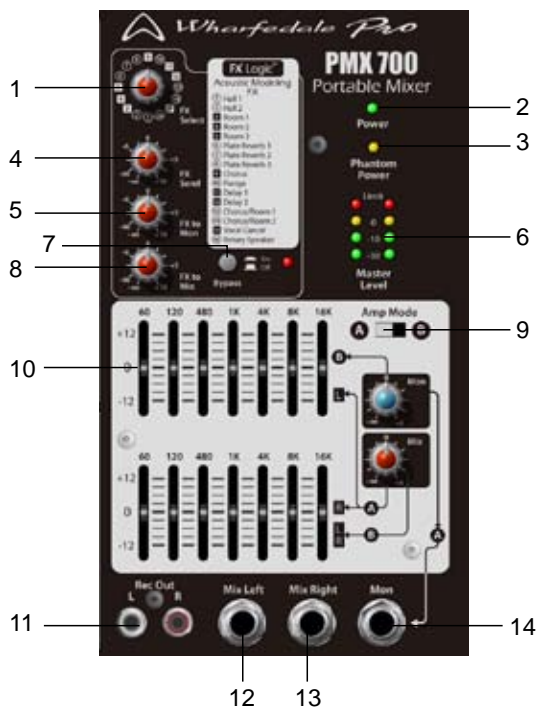

1. FX Select - Selects the effect type that will be used
2. Power LED - Indicates AC supply
3. Phantom Power LED - Indicates +48v phantom powering is supplied to all of the XLR inputs. Please check that all connected microphones can withstand +48v power input
4. FX Send - Allows for master adjustment of the FX send buss
5. FX to Mon - Routes the FX processor output to the Monitor send
6. Master Level LED's - 4 segment LED metering for the master buss, if the limit LED illuminates constantly lower the master level to avoid damage to your loudspeakers
7. Bypass - Used to switch the internal FX processor on or off

8. FX to Mix - Controls the output level of the internal FX processor to the master buss
9. Amp Mode - Configures the signal routing of the graphic EQ. With Mode 'A' each EQ controls each respective output with the monitor sends routed unprocessed to the Mon output. In Mode 'B' The Mon is processed by the top EQ and the lower EQ controls will process both left and right output channels.
10. 7-band EQ - 2 independent 7-band equalisers with flexible A/B routing
11. Rec Out - Line level output using phono connectors, provides connection to recording devices
12. Mix Left - Balanced / unbalanced ¼" TRS master output for the left channel
13. Mix Right - Balanced / unbalanced ¼" TRS master output for the right channel
14. Mon - Balanced / unbalanced ¼" TRS Monitor send output

PMX 700 / PMX 710 REAR PANEL



1. Speakon™ outputs - For connection to your loudspeakers
2. Power Switch - Turns the unit on or off, ensure that AC is supplied and that the levels have been turned down to protect your speakers
3. Phantom Power switch - Activates the +48v phantom powering for the 4 XLR inputs
4. IEC receptacle - Allows input of the supplied IEC lead for AC supply

PMX500 DIMENSIONAL DRAWINGS

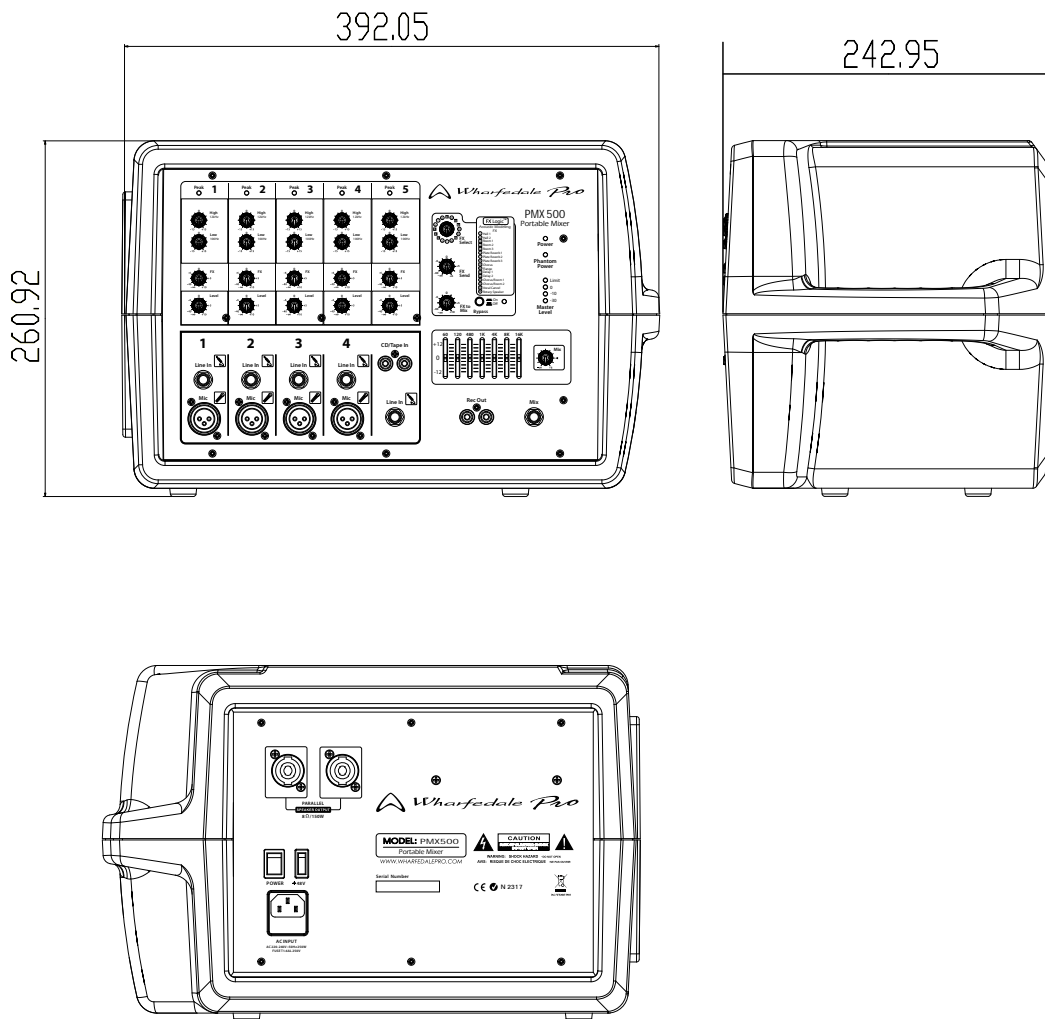

PMX700 DIMENSIONAL DRAWINGS

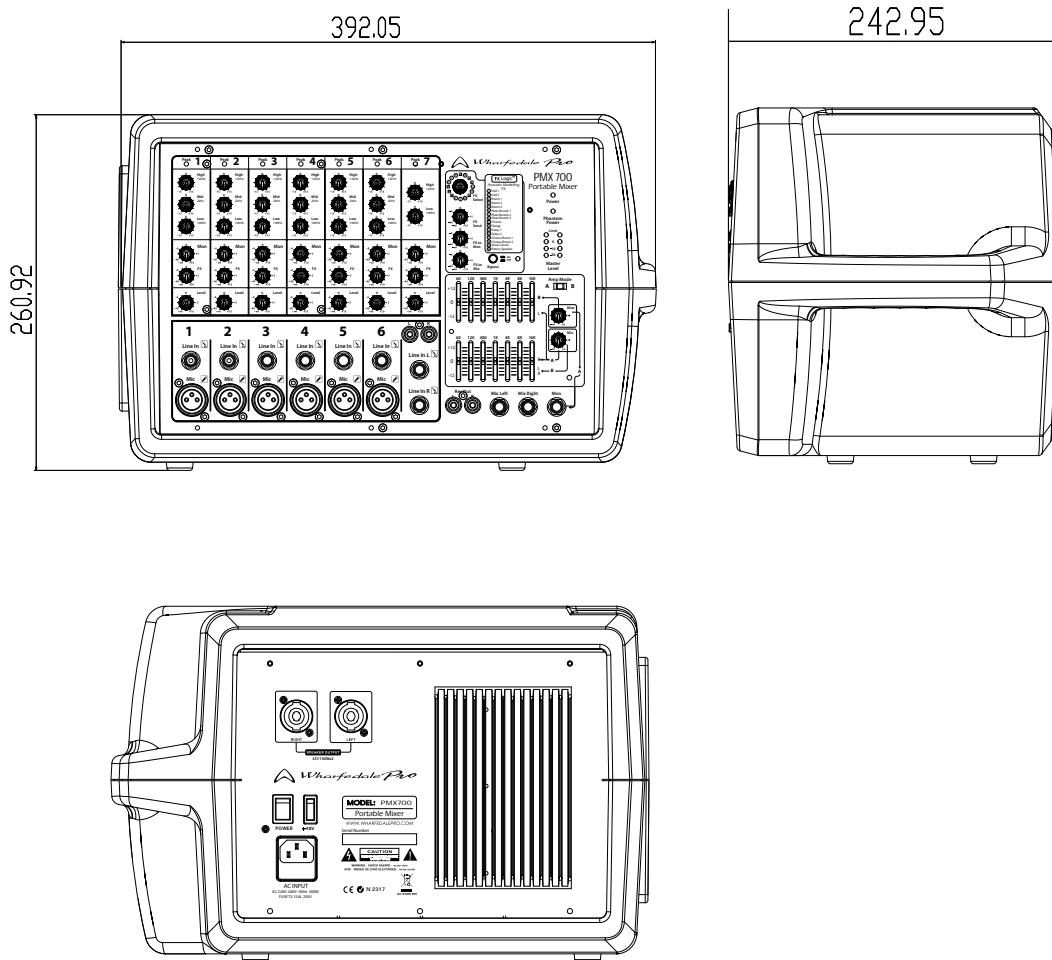

PMX710 DIMENSIONAL DRAWINGS

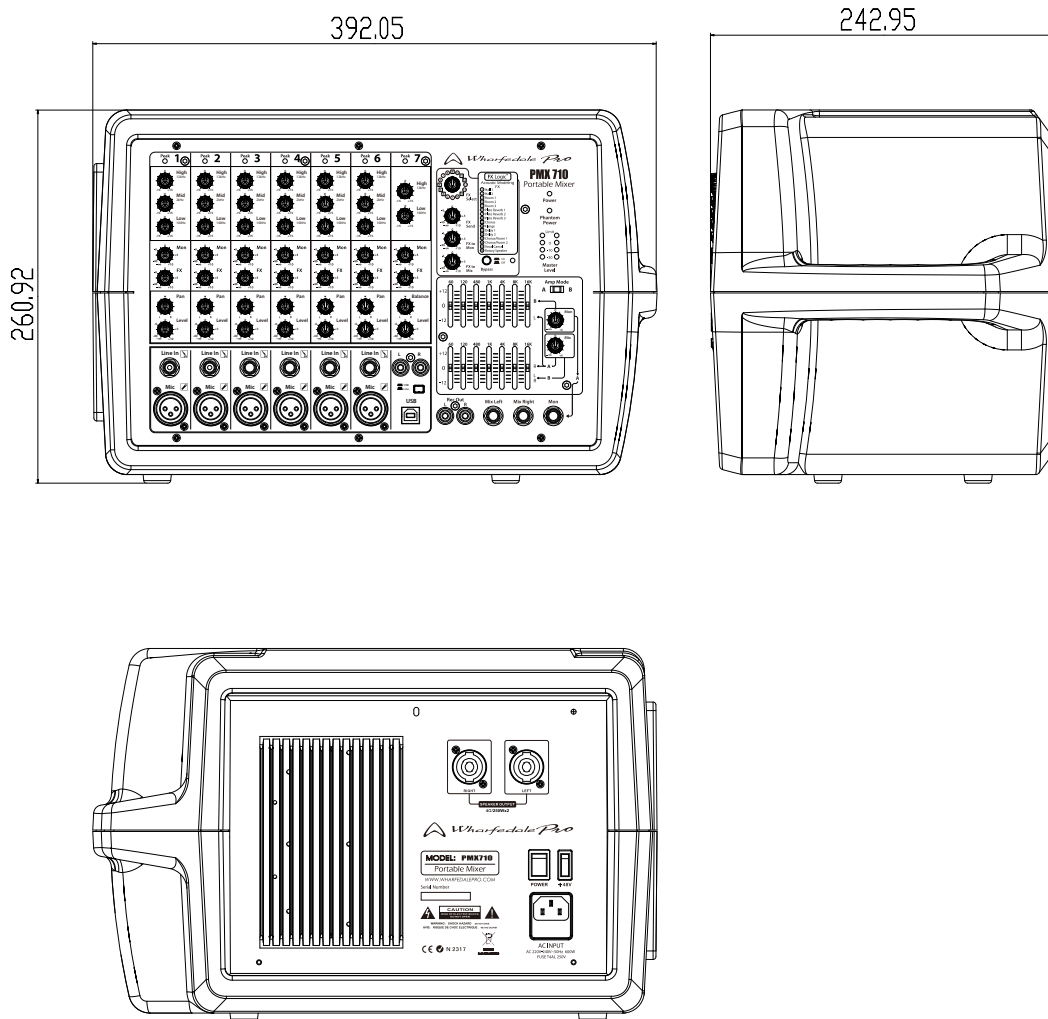

PMX SYSTEM OVERVIEW

The Wharfedale Pro PMX System provides you with everything you need to get up and running for a public performance.

- **1x PMX powered mixer**
- **2x PT-X 2-way loudspeakers**
- **1x DM 1.0 dynamic microphone**
- **1x 4.5m microphone cable**
- **2x speaker cables**

A PMX System package comprises of a PMX powered mixer (PMX500 or PMX700), a pair of 2-way loudspeakers (PTX-8 with the PMX 500 System and PTX-12 with the PMX700 System), a DM1.0 dynamic microphone and the necessary cables to connect the system.

Setting up a PMX System has been designed to be simple even for absolute beginners. Connect the components as shown in the wiring diagram to create a basic vocal PA. Adding more equipment is simple, always consult the user manual of any 3rd party equipment to ensure you will get the best performance.

QUICK START GUIDE

In order to get up and running with your PMX System follow the steps below:

1. Zero the mixer. This involves setting all level and send controls to minimum and all EQ controls to 0dB.
2. Make all connections for audio and power as per the wiring diagrams:
 1. Ensure that the power switch is on the off position before connecting the AC supply.
 2. Connect the microphone using the supplied XLR cable
 3. Connect each speaker to the main outputs using the supplied speaker cables
3. If your microphones require phantom power use the rear panel switch to activate +48V supply.
4. Turn the power switch on.
5. Raise the level control for each of your connected sources, ensure that the Peak LED does not constantly illuminate.
6. Raise the Mix Level control until you achieve the desired Sound Pressure Level (SPL).

NOTE

If the sound becomes distorted at higher volumes you may need to add extra equipment to achieve the desired SPL, otherwise you may cause permanent damage to your system by overloading it.

USB INTERFACE

The USB connector enables computers with USB connectivity to interface directly with the PMX 710 mixer for full duplex recording and playback. In recent years the introduction of USB connectivity has ushered a new appreciation of the capabilities of computer audio, helping to fuse both digital and analogue and open up endless possibilities for the recording musician.

The internal AD (Analogue to Digital) and DA (Digital to Analogue) converters are 16-bit/48KHz enabling recording and playback above CD quality, ensuring that recordings that you make with a PMX 710 have outstanding quality.

The PMX 710 is fully class compliant and requires no drivers when used with modern operating systems. Mac OSX, Windows XP, Vista and 7 will require no additional driver software.

Windows XP Installation

Simply choose the device in the following location: Start/Settings/Control Panel/Sounds and Audio Devices/Audio

Mac OSX Installation

Simply select as an input and output device using the "Audio MIDI Setup" page, you can find this easily using the spotlight function.

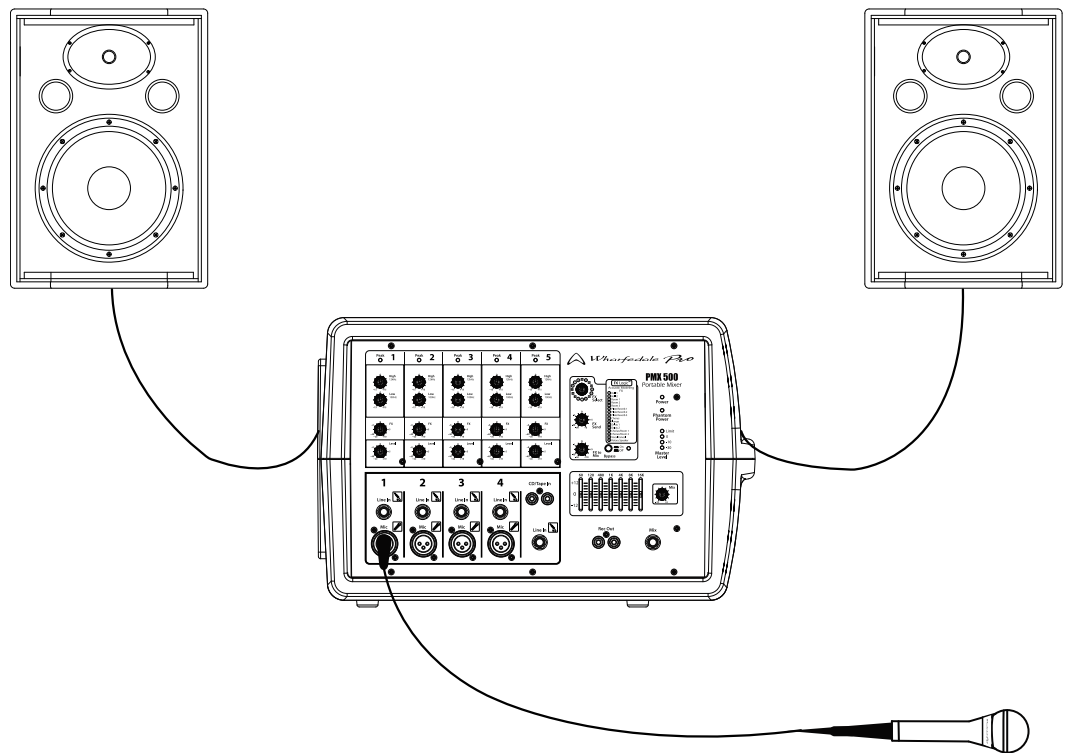
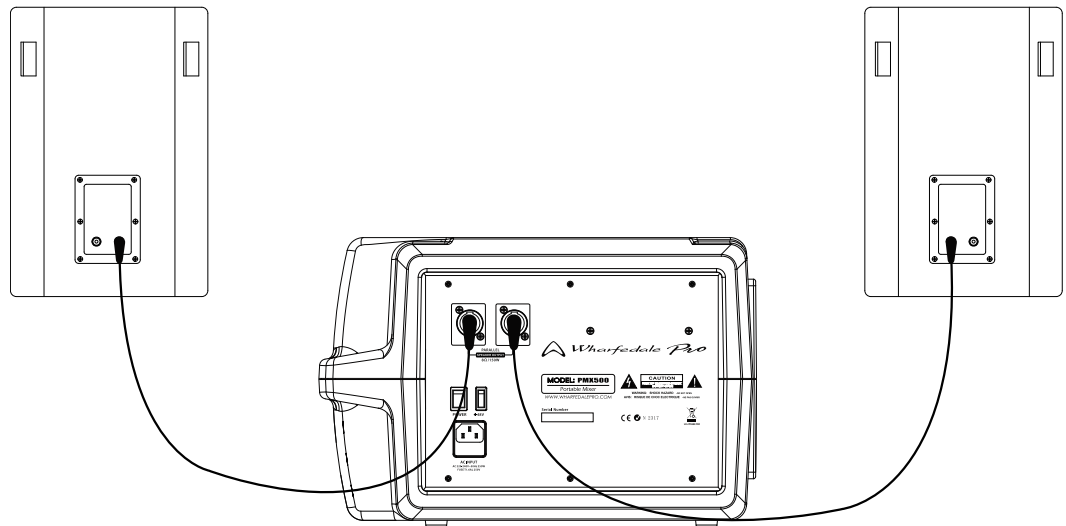

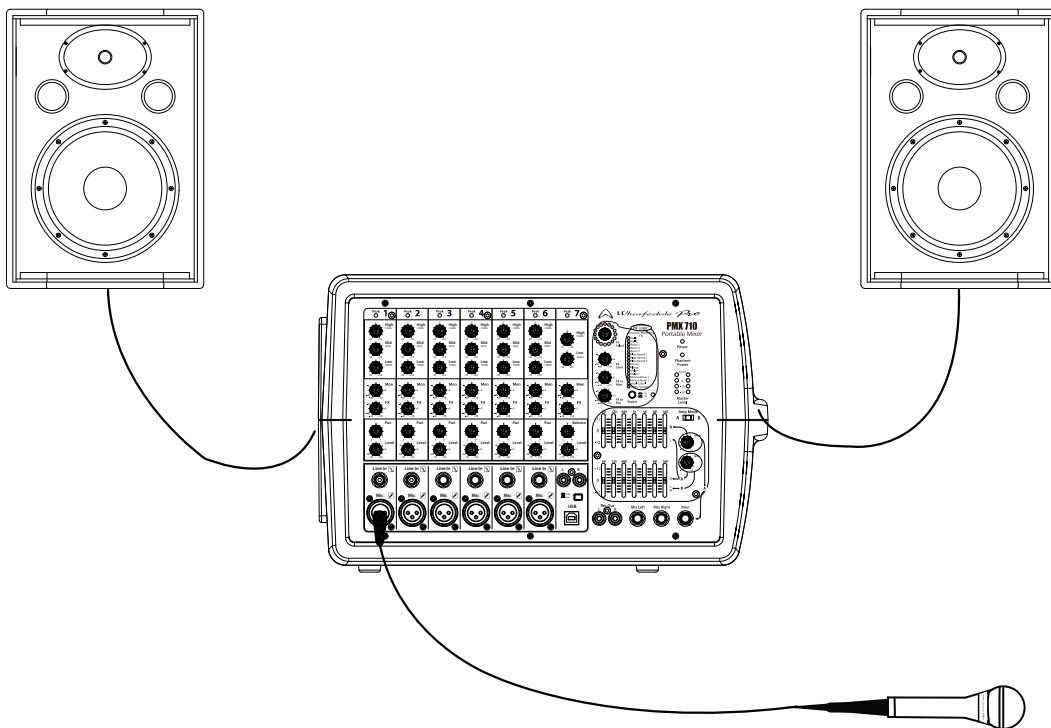
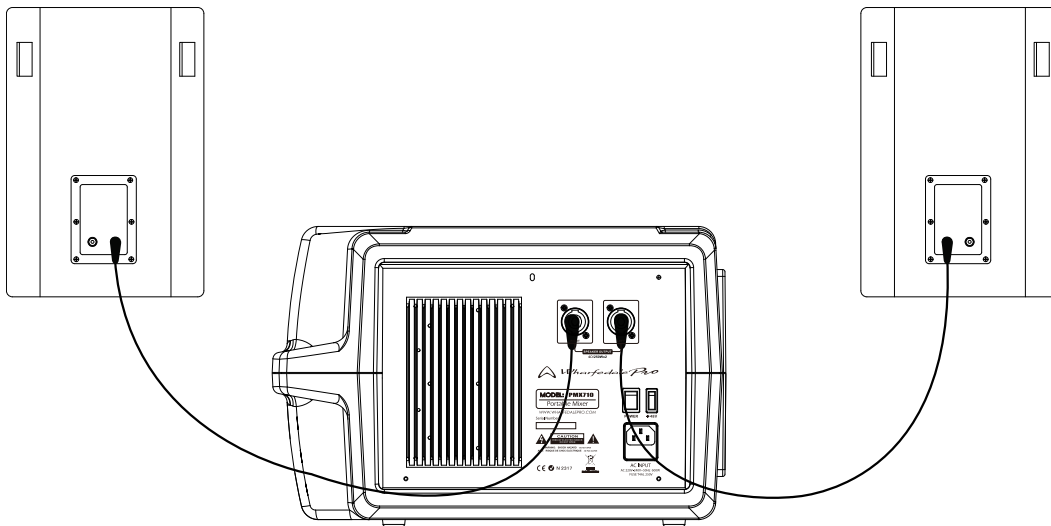

PMX500 BLOCK DIAGRAM

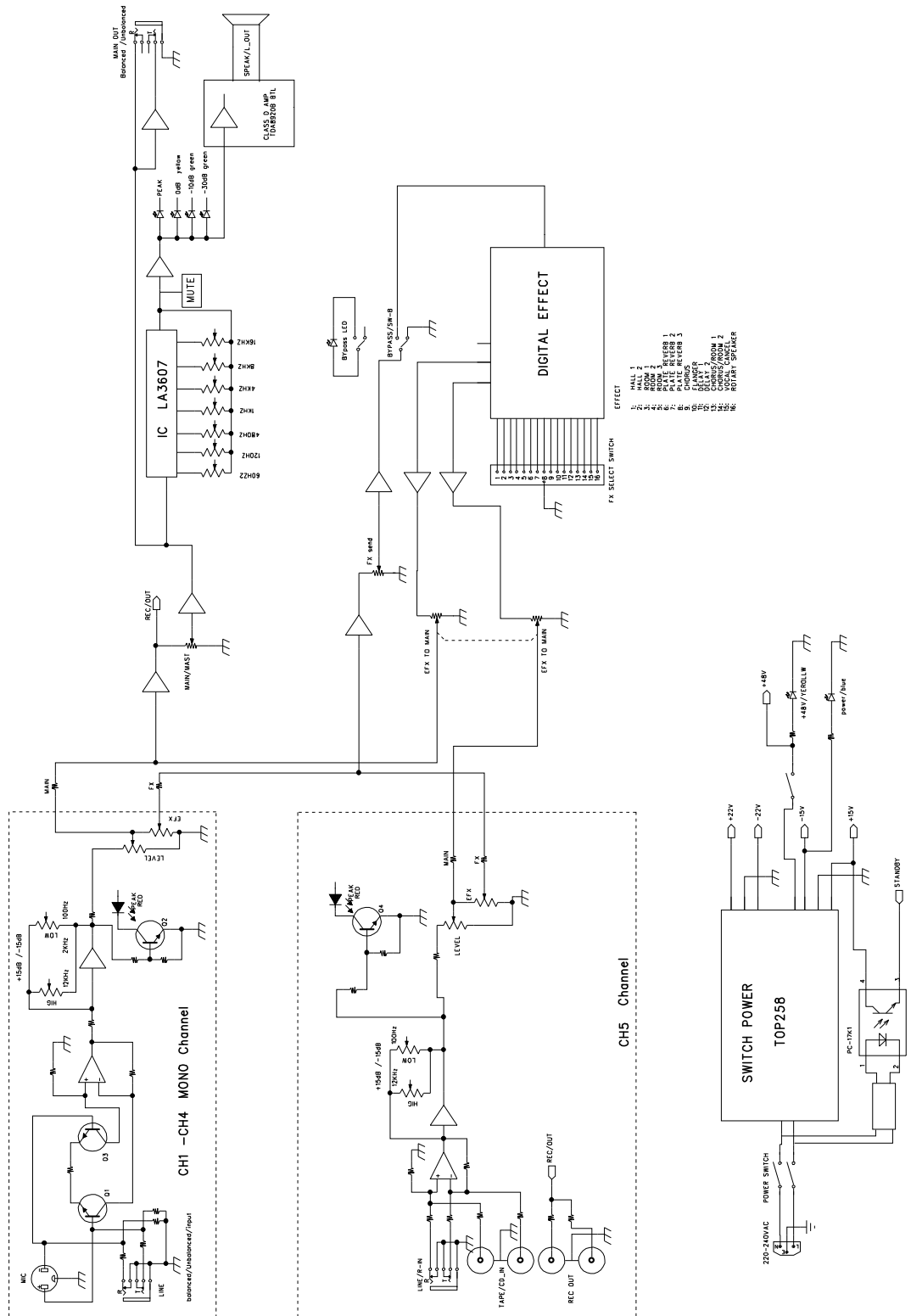

PMX700 BLOCK DIAGRAM

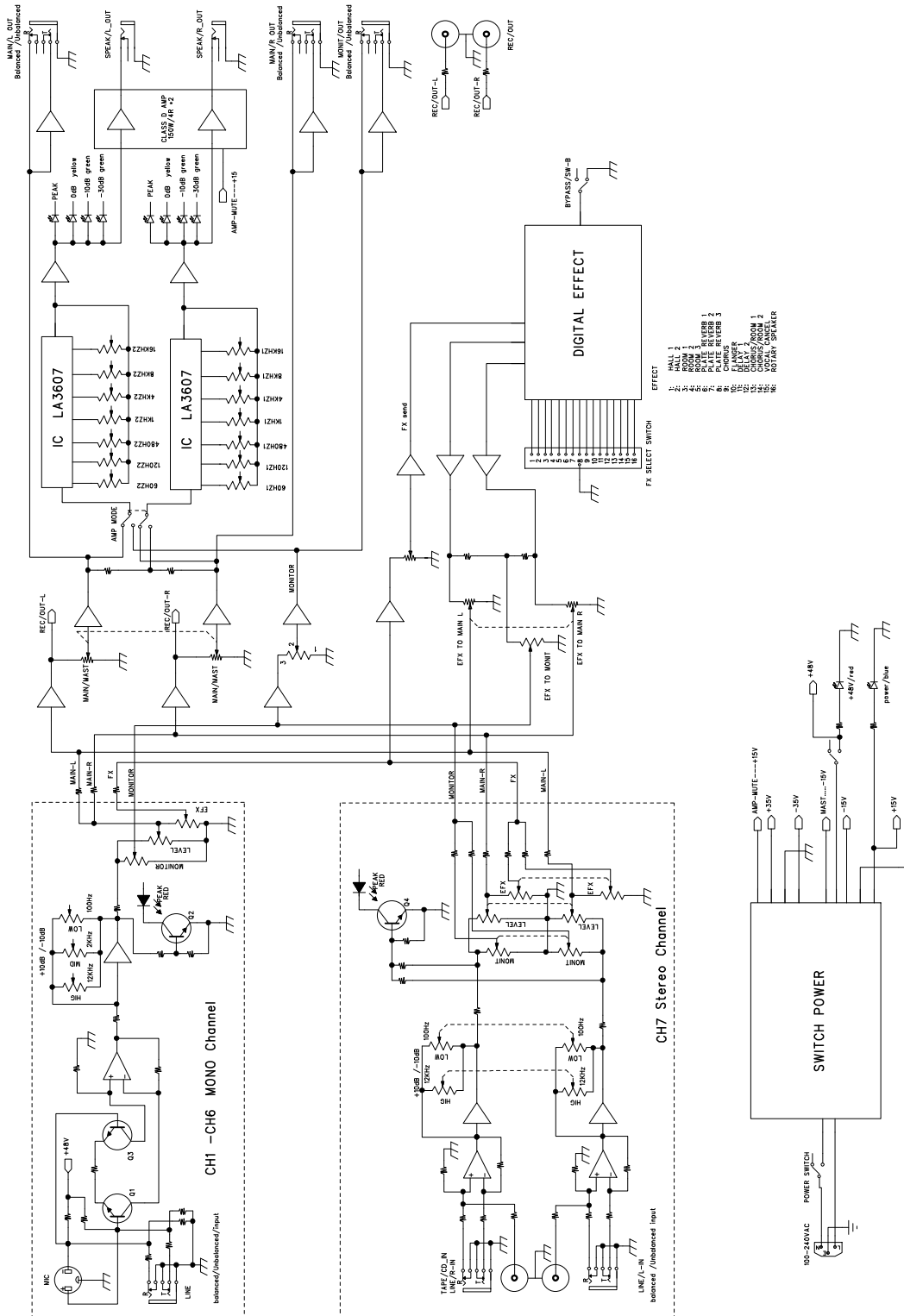

PMX710 BLOCK DIAGRAM

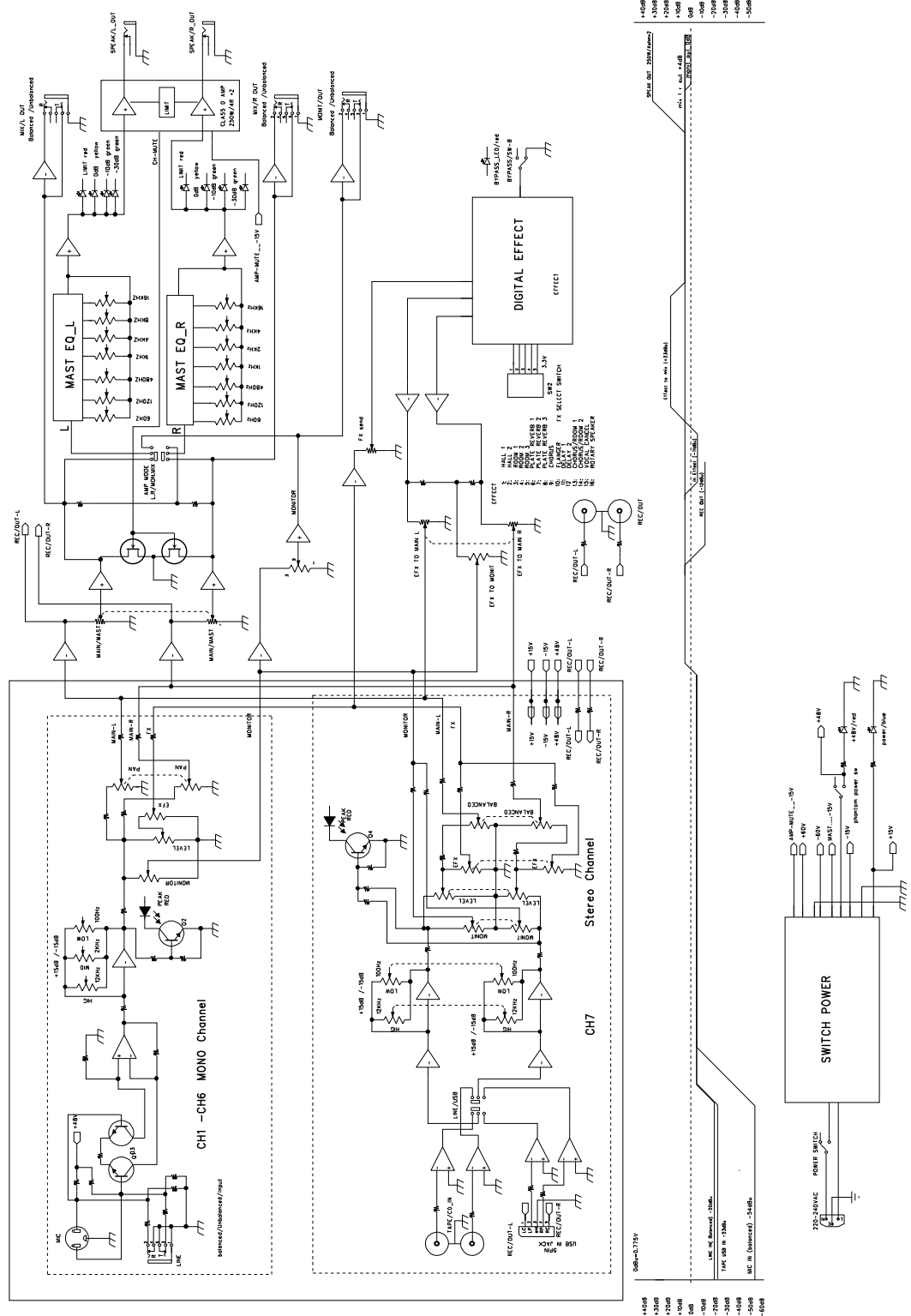

SPECIFICATIONS

Model	PMX 500
Power Output	150W RMS into 4Ω
Maximum output level	+22dBu (mix out (balanced))
Total harmonic distortion:	≤0.4% @ 40Hz-20KHz 100w/4Ω (speaker out) ≤0.02% @ 20Hz-30KHz +14dBu (mix out)
Hum & noise	-50dB residual output noise (speaker out) -83dB residual output noise (mix out)
Maximum voltage gain	82dB input mic to speakers out 52dB input mic to mix out 42dB input mic to rec out 52dB input line to speakers out
Input channel equalisation	±15dB maximum High 12kHz shelving Low 100Hz shelving
Graphic equaliser	7 bands (60Hz, 120Hz, 480Hz, 1KHz, 4KHz, 8KHz, 16kHz) max: ±12dB
Level meter	4-segment LED (0dB output 0dBu on meter mix output)
Limit indicator	Turns on approx +6dBu {Comp ≥140W (speakers out) / each CH}
Digital effects	16 Effects (Hall1; Hall2; Room1; Room2; Room3; Plate Reverb1; Plate Reverb2; Plate Reverb3; Chorus; Flange; Delay1; Delay2; Chorus/Room1; Chorus/Room2; Vocal Cancel; Rotary Speaker)
Power	AC100-120V~/220-240V, 50/60Hz
Product dimension (H x W x D)	392 x 261 x 243mm
Carton dimension (H x W x D)	440 x 295 x 329mm
Net weight	4.65 kg
Gross weight	5.85 kg

SPECIFICATIONS

Model	PMX 700
Power Output	150W x 2 RMS into 4Ω
Maximum output level	+22dBu (mix out (balanced))
Total harmonic distortion:	≤0.4% @40Hz-20kHz 100w/4Ω (speaker.out) ≤0.02% @20Hz-30kHz +14dBu (mix monitor out)
Hum& noise	-50dB residual output noise (speaker out) -83dB residual output noise (mix/monitor out)
Maximum voltage gain	82dB input mic to speakers out 52dB input mic to mix / monitor out 42dB input mic to rec out 52dB input line to speakers out
Input channel equalisation	±15dB maximum High 12kHz shelving Mid 2kHz shelving Low 100Hz shelving
Graphic equaliser	7 bands (60Hz, 120Hz, 480Hz, 1KHz, 4KHz, 8KHz, 16kHz) max: ±12dB
Level meter	4-segment LED x2 (0dB output 0dBu on meter mix L/R)
Limit indicator	Turns on approx +6dBu {Comp ≥140W (speakers out) / each CH}
Digital effects	16 Effects (Hall1; Hall2; Room1; Room2; Room3; Plate Reverb1; Plate Reverb2; Plate Reverb3; Chorus; Flange; Delay1; Delay2; Chorus/Room1; Chorus/Room2; Vocal Cancel; Rotary Speaker)
Power	AC100-120V~/220-240V, 50/60Hz
Product dimensions (H x W x D)	392 x 261 x 243mm
Carton dimensions (H x W x D)	440 x 295 x 329mm
Net weight	5.45 kg
Gross weight	6.65 kg

SPECIFICATIONS

Model	PMX 710
Power Output	250W x 2 RMS into 4Ω
Maximum output level	+28dBu (mix out (balanced))
Total harmonic distortion:	≤0.4%@40Hz-20kHz 100w/4Ω(speakers out) ≤0.02%@20Hz-30kHz +14dBu(mix/monitor out)
Hum& noise	-50dB residual output noise(speakers out) -83 dB residual output noise(mix/monitor out)
Maximum voltage gain	88dB input mic to speakers out 58dB input mic to mix/monitor out 48dB input mic to rec out 54dB input line to speakers out 58dB input tape&usb to speakers out
Input channel equalisation	+/-15 dB maximum High 12kHz shelving Mid 2kHz shelving Low 100Hz shelving
Graphic equaliser	7bands(60Hz, 120Hz, 480Hz ,1kHz, 4kHz, 8kHz ,16kHz) Max: +/-12 dB
Level meter	4-Segment LED x2 (0dB output 0dBu on meter mix L/R)
Limit indicator	Turns on approx +6 dBu {Comp ≥240W (speakers out) / each CH}
Digital effects	16 Effects(Hall1, Hall2, Room1, Room2, Room3,Plate Reverb1, Plate Reverb2, Plate Reverb3,Chorus, Flange, Delay1, Delay2, Chorus/Room1, Chorus/Room2,Vocal Cancel, Rotary Speaker)
Power	AC100-120V~/220-240V, 50/60Hz
Product dimension (H x W x D)	392 x 261 x 243mm
Carton dimension (H x W x D)	440 x 295 x 329mm
Net weight	5.7 kg
Gross weight	6.9 kg

MODEL	PT-X8	PT-X12
Frequency response (+/- 10dB)	65-20kHz	55-20kHz
Frequency response (+/- 3dB)	70-20kHz	60-20kHz
Power handling		
Continuous	75W	250W
Programme	150W	500W
Peak	300W	1000W
Nominal Impedance	8Ω	4Ω
Sensitivity (dB SPL @ 1W / 1M)	95dB	97dB
Max SPL (Calculated)	119dB	126dB
Nominal coverage (HxV)	90°x60°	90°x60°
Crossover frequency	3.0kHz	3.0kHz
Woofers	205mm/8"	305mm/12"
LF Power (RMS)	75w	250w
Sensitivity (free field 1W @ 1M)	95dB	97dB
LF Voice coil	1.5"	2"
Cone material	Paper	Paper
LF Voice coil material	Copper	Copper
LF Voice coil former material	Fibre glass	Fibre glass
Basket material	Steel	Steel
Basket type	Pressed	Pressed
Magnet structure mass	0.792kg/1.73lbs	1.24kg/2.7lbs
Magnet structure material	Ferrite	Ferrite
LF Driver part number	ZD-75600-01R	L01-07010065A
HF Power (RMS)	25W	25W
Sensitivity (free field 1W @ 1M)	107dB	107dB
HF Voice coil	1"	1"
Waveguide Type	Elliptical	Elliptical
Waveguide Exit	1.2"	1.2"
Diaphragm material	Phenolic	Phenolic
HF Voice coil former material	Kapton	Kapton
Magnet structure mass	0.365kg/0.803lbs	0.365kg/0.803lbs
Magnet structure material	Ferrite	Ferrite
Protection	PTC	PTC
HF driver part number	ZD-53200-01R	ZD-53200-01R
Enclosure Material and Thickness	12mm particle	12mm particle
Enclosure Finish	Black carpet	Black carpet
Enclosure Volume	14.3L	31.8L
Grille Material & Finish	1.2mm steel	1.2mm steel
Pole mount	35mm	35mm
Handles	2 on sides	2 on sides
Input Connector Type	2x1/4" phone Jack	2x1/4" phone Jack
Net Weight		
kg	8.1	12.85
lbs	17.8	25.7
Dimensions (Unpacked)		
H	429mm / 16.9"	525mm / 20.7"
W	280.7/146.7mm / 11.1/5.8"	370.7/207.3mm / 14.6"/ 8.2"
D	250mm / 9.8"	305mm / 12"

PMX System Microphone	DM1.0
Frequency response	50Hz-18kHz
Type	Dynamic
Magnet material	Neodymium
Polar pattern	Cardioid
Output connector	3-pin gold plated balanced male XLR

WHARFEDALE PRO LIMITED WARRANTY

Wharfedale Pro PMX Series products are warranted of manufacturing or material defects for a period of one year from the original date of purchase. In the event of malfunction, contact your authorized Wharfedale Pro dealer or distributor for information.

*Be aware that warranty details may differ from country to country. Contact your dealer or distributor for information. These terms do not infringe your statutory rights.



Wharfedale Professional

IAG House, 13/14 Glebe Road, Huntingdon, Cambridgeshire, PE29 7DL, UK

www.wharfedalepro.com

Wharfedale Professional reserves the right to alter or improve specifications without notice.
All rights reserved © 2011 Wharfedale Pro. Wharfedale Pro is a member of the IAG Group.