

7. SPECIFICATION

Model	BS-S20B AS	BS-S20W AS
Continuous Program input	40 W	
Impedance	8 Ω	
Sensitivity	87 dB (Pink noise 330 Hz ~ 3,300 Hz / 1 W, 1 m)	
Frequency response	150 ~ 20,000 Hz (-20 dB below SPL)	
Speaker component	8cm (3") cone-type	
Connection	Push-in terminal	
Finish	Enclosure : HIPS Resin, black	Enclosure : HIPS Resin, white
	Front Cover : HIPS Resin, black	Front Cover : HIPS Resin, white
	Bracket : Steel plate, paint, black	Bracket : Steel plate, paint, white
Dimensions	92 (W) x 97.5 (H) x 100 (D) mm (3.62" x 3.84" x 3.94")	
Weight	600 g (1.32 lb) (without bracket)	
Accessories	Speaker Bracket (set)...1pc	
	Hexagonal bolts M5 x 12 (with washer and spring washer)...2pcs	

※ The specification may change without notice for improvement

TOA

BOX SPEAKER

INSTRUCTION MANUAL

BS-S20B AS
BS-S20W AS

1. SAFETY PRECAUTIONS

- Read carefully the manual before installing or using the speaker unit.
- Please understand thoroughly the safety instructions and other important notes pertaining to safety stated in the manual.
- Keep the manual for future reference after you have finished reading.



WARNING

Indicates a potentially hazardous situation which, if mishandled, could result in death or serious personal injury.



CAUTION

Indicates a potentially hazardous situation which, if mishandled, could result in moderate or minor personal injury, and/or property damage.



WARNING

Installation of speaker unit on bracket

- Install the unit on a location which is secure enough to support the speaker unit and mounting brackets. Failure to do so may cause the speaker unit to fall and inflict injury to people / damage the equipment.
- Do not apply other methods to mount the bracket other than the method stated in the manual. Speaker unit may fall and cause injury to people.
- Use the proper screws in accordance with the composition and structure of the ceiling or wall. Failure to do so may cause the speaker to fall and inflict injury to people.
- Tighten the screws properly. Ensure the bolt is tightened securely after the speaker unit is installed to prevent it from falling and inflicting injury to people.
- Do not install on an unstable location which may cause the speaker unit to fall due to the strong or continuous vibration.
- The speaker is designed for indoor use, do not install outdoors. Failure to do so may cause damage on the speaker unit and or cause it to fall which may inflict injury to people. Speaker is also prone to rain which may cause short-circuit.
- Do not install the speaker in a room without proper ventilation. Bracket will get rusty easily which may cause the speaker to fall and inflict injury to people.

- Do not use anti-corrosion liquid. Anti-corrosion on plastic (resin) or rubber may cause damage on the speaker unit. The speaker unit may fall and inflict injury on people



CAUTION

During Installation of Speaker Unit

- Be careful of the sharp edges of the unit which may cause injury.
- To prevent short-circuit, ensure the amplifier is always in the OFF condition when connecting it to the speaker unit.

When Speaker Unit is in use

- Do not place any heavy item on the speaker because it may cause the speaker to fall which may cause injury to people or damage on the equipment. The heavy item may also fall and endanger safety.
- Do not operate the speaker for long duration of time with distorted sound. This indicates false operation and it may introduce heat which subsequently may cause fire.
- Do not sit, stand on or dangle from the speaker unit because it may cause the speaker to fall and inflict injury to people as well as damage the equipment.
- Do regular check of the equipment for early detection of any damage on the speaker unit or corrosion on the mounting bracket. Failure to do so may cause the speaker unit to fall and inflict injury to people.

Traceability Information for Europe

Manufacturer:
TOA Corporation
7-2-1, Minatojima Nakamachi, Chuo-ku, Kobe, Hyogo,
Japan

Authorized representative:
TOA Electronics Europe GmbH
Suederstrasse 282, 20537 Hamburg,
Germany

URL: <http://www.toa.jp/>

2. GENERAL DESCRIPTION

- The box speaker model BS-S20 series is a compact speaker that suitable for indoor use only.
- The wide range of frequency as well as capability of generating high sound pressure level, make it an efficient speaker to be used in a spacious room.
- Speaker's characteristic is full range, very compatible if to be joined with subwoofer as satellite speakers.
- The provided brackets allow the speaker to be mounted on various location with direction radiations according to necessary.
- The mounting brackets come together with the product as accessories.

3. DESCRIPTION ON OVERLOAD PROTECTION

The speaker unit is equipped with an overload protector. The system shall protect the speaker unit from overload input which exceeds the allowed capacity.

Speaker's volume will turn lower if the input to the speaker exceeds the maximum capacity of speaker.

In such event, please turn down the amplifier's volume to the minimum level and wait for 10 seconds. the system shall automatically reset to normal condition. You may then gradually readjust the amplifier's volume to the level lower then previous volume.

Important Note!

The system does not entirely protect against overload. Prolonged overload input to the speaker unit cause the system to malfunction. As such, the overload input will flow in and damage the speaker unit.

It is important to prevent prolonged overload input exceeding the maximum limit from flowing into the speaker unit.

4. DIMENSIONAL DIAGRAM

4.1. SATELLITE SPEAKER

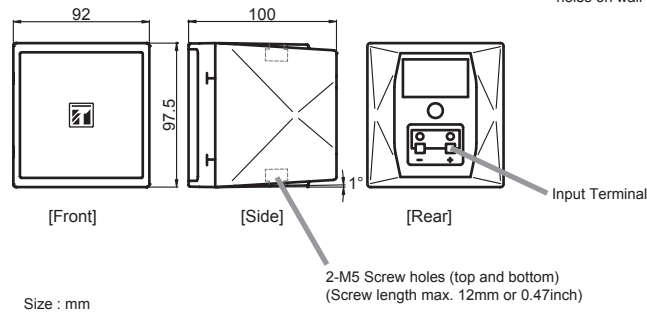
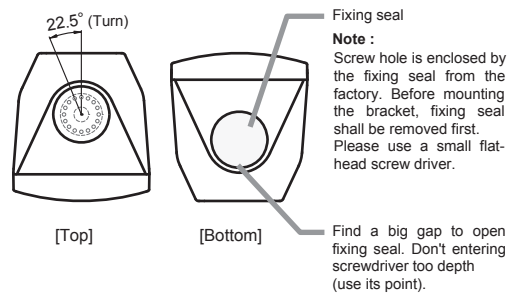

4.2. BRACKET (TO MOUNT SPEAKER)

Loosen the tightening screw (right and left) to install the bracket to the speaker unit. Take note of Bracket-A, this is part of the bracket which will be attached to the wall or ceiling when installing the speaker unit.

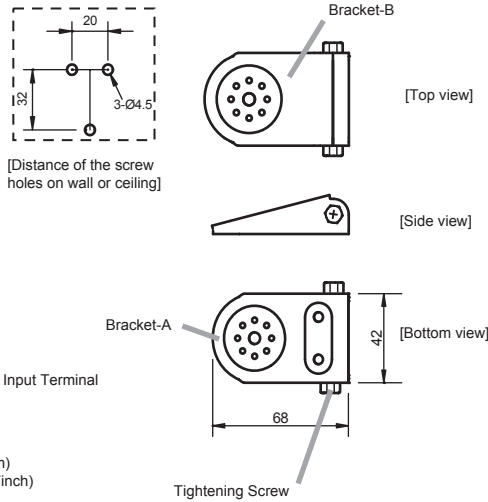

5. SPEAKER CABLE CONNECTIONS

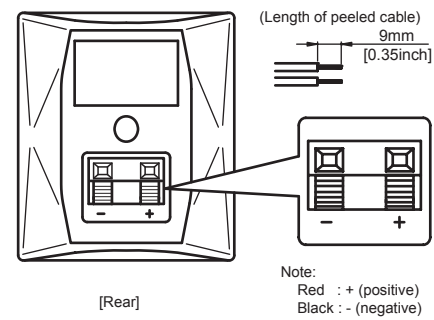

6. INSTALLATION

6.1. Speaker Unit installation without bracket

Place the speaker unit on an even and flat surface. If the speaker unit is placed on slippery surface, you may want to cover the surface with a cloth to prevent the speaker from moving.

6.2. Speaker Unit installation with bracket

Before installing the bracket to speaker unit, remove / open the fixing seal enclosing the screw holes. Use a small flat head screwdriver. Place the flat head screwdriver into the fixing seal slot (see image 4.1.). For installation of single system, please remove only one fixing seal and for double system, please remove two fixing seals (top and below) on one of the speaker units.

6.2.1. Installation on Wall

A. [single-system installation sample]

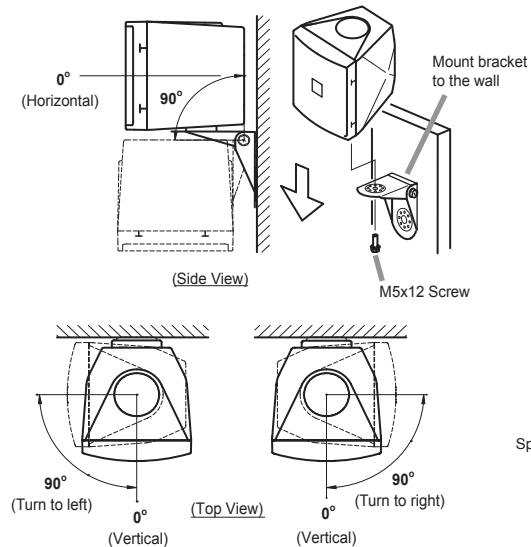

B. [double-system installation sample]

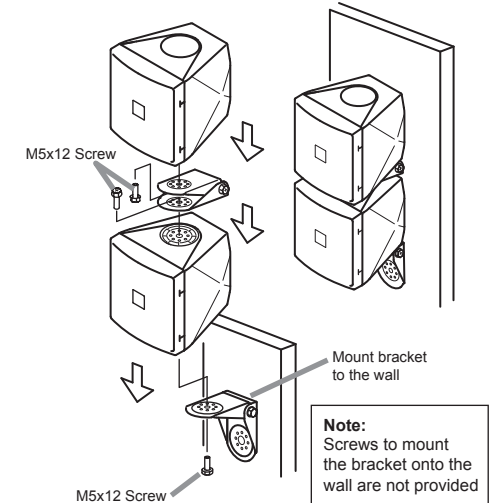

6.2.2. Installation on Ceiling

A. [single-system installation sample]

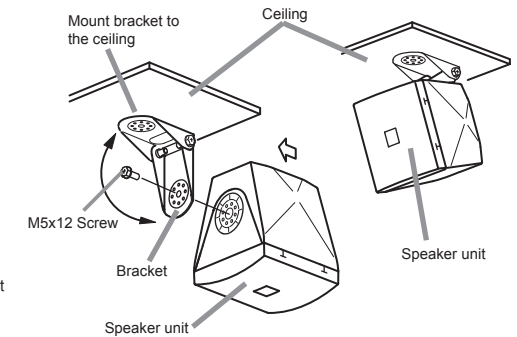

B. [double-system installation sample]

