

e 604 Cardioid instrument microphone for drums, percussion, brass and woodwinds

FEATURES

- Rugged reinforced glass fiber body
- Low sensitivity to impact and handling noise
- Very high sound pressure handling capability (in excess of 160 dB)
- Low distortion microphone
- Hum compensating coil
- Easy to position due to compact design
- Integral stand mount

The frequency response and cardioid pick-up pattern are optimized for drum sets and other percussion instrument miking, while also producing exceptional results on all forms of brass and woodwind. An integral stand mount screws directly onto mic stands and included clip attaches mic to rims of drums. Very high sound pressure level handling, in excess of 160 dB, is combined with a balanced, clear, low distortion signal. Lightweight voice coil provides extended high frequency and rapid transient response. A tough reinforced glass fiber body takes the knocks and shocks.



ARCHITECT'S SPECIFICATIONS

The instrument microphone shall be a dynamic cardioid designed for use with drums and percussion as well as brass and woodwind instruments.

It shall have a compact design and a rugged reinforced glass fiber body and shall feature an integral stand mount. The microphone shall be fitted with a hum compensating coil. The frequency response shall be 40 Hz – 18,000 Hz and the sensitivity (free field, no load) shall be 1.8 mV/Pa at 1 kHz. Nominal impedance shall be 350 Ω, with a min. terminating impedance of 1 kΩ.

The microphone shall provide a 3-pin XLR connector. Dimensions shall be 33 x 59 mm (1.3" x 2.32"). Weight without cable shall be 60 grams (2.12 oz). The microphone shall be the Sennheiser e 604.

TECHNICAL DATA

Transducer principle	dynamic
Pick-up pattern.....	cardioid
Frequency response	40 – 18,000 Hz
Sensitivity (free field, no load at 1 kHz)	1.8 mV/Pa
Nominal impedance.....	350 Ohm
Min. terminating impedance.....	1000 Ohm
Connector.....	XLR-3
Dimensions.....	∅ 33 x 59 mm
Weight w/o cable.....	60 g

DELIVERY INCLUDES

- 1 e 604
- 1 Drum clip
- 1 Pouch
- Instructions for use

e 604 Cardioid instrument microphone for drums, percussion, brass and woodwinds

FREQUENCY RESPONSE

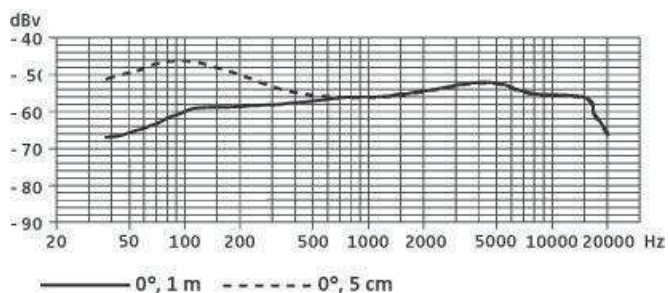

POLAR PATTERN

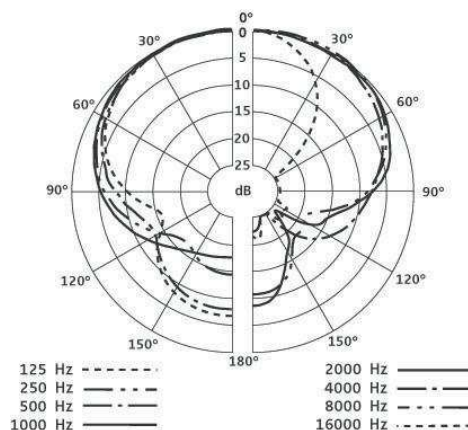

DIMENSIONS

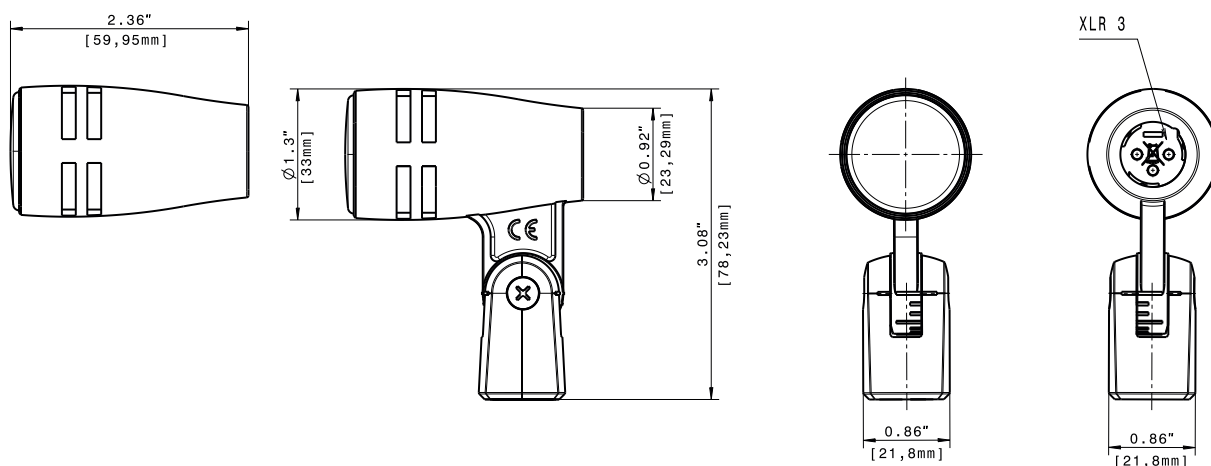

PRODUCT VARIANTS

e 604 N

RECOMMENDED ACCESSORIES

MZH 504 – quick mount drum clamp for e 604	Art.-No. 004181
MZH 604 – improved L-shaped drum clamp for e 604, e 904	Art.-No. 005299
MZJ 504 – swivel joint kit to convert swivel mounts to double swivel	Art.-No. 075549

Sennheiser electronic GmbH & Co. KG
Am Labor 1, 30900 Wedemark, Germany
www.sennheiser.com

 **SENNHEISER**