

Blackline X10

Compact Passive Two-Way System



Features

- Compact passive two-way system
- Symmetrical multi-angle plywood enclosure
- User-rotatable 90° x 50° horn
- Vertical and horizontal orientation
- Screw-free, cloth-backed perforated steel grille
- Integral ergonomic handle
- Pole-mount bung maintains clean lines
- 8Ω nominal impedance
- Twin NL4 connectors
- Flexible mounting options via M8 inserts



Applications

- Portable sound reinforcement
- Bars and restaurants
- Nightclubs
- Unobtrusive stage monitoring
- Corporate AV events and conferences
- Weddings and parties
- Main PA infill
- Secondary stages at festivals
- Houses of Worship, leisure centres and retail outlets

The X10 is a high performance yet very compact two-way passive loudspeaker system which utilises a 10" (250mm)/2.5" (63mm) voice coil LF driver and a 1" (25mm) exit HF compression driver with a 1.4" (35mm) polyimide diaphragm. The rotatable 90° x 50° HF horn has equal horizontal and vertical mouth dimensions for directivity control in both planes.

It has a multitude of professional applications — from distributed sound reinforcement, Houses of Worship and AV events to frontfill/infill and use as an unobtrusive stage monitor. With a maximum SPL of 124dB @ 1m, it is uniquely placed to meet the foreground requirements of music bars and clubs that require upfront sound levels from a very compact enclosure. Use with a BlacklineX Series subwoofer will enable the X10 to operate as small dancefloor or sound reinforcement system that is remarkably powerful for its size, as well as being extremely portable.

The X10 is constructed from plywood and fitted with a screw-free steel grille, M8 inserts for wall brackets and eyebolt suspension, plus a pole-mount socket with a removable bung that maintains clean lines in install applications. Finished in black textured paint.

A full-range passive two-way system, the X10 may be used without a controller. However, the EQ and limiter functions of a controller such as the Martin Audio DX0.4 or DX0.6 will maximise its capabilities and provide crossover functions when used with a subwoofer such as the X115 or SX210.

Martin Audio Ltd
Century Point, Halifax Road, High Wycombe
Buckinghamshire HP12 3SL, England

Telephone: +44 (0) 1494 535 312
Facsimile: +44 (0) 1494 438 669
Email: info@martin-audio.com



Blackline X10

Compact Passive Two-Way System



Technical Specifications

TYPE	Compact, passive two-way system
FREQUENCY RESPONSE (5)	65Hz-20kHz \pm 3dB -10dB @ 55Hz
DRIVERS	LF: 10" (250mm)/2.5" (63.5mm) voice coil, ferrite motor system HF: 1" (25mm) exit/1.4" (35mm) voice coil, polyimide dome compression driver
RATED POWER (2)	250W AES, 1000W peak
RECOMMENDED AMPLIFIER	VIA2502 or VIA2004
SENSITIVITY (8)	94dB
MAXIMUM SPL (9)	118dB continuous, 124dB peak
NOMINAL IMPEDANCE	8 ohms
DISPERSION (-6dB)	90° H x 50° V (user-rotatable)
CROSSOVER	2.4kHz passive
ENCLOSURE	Multi-angle birch/poplar ply
FINISH	Black textured paint
PROTECTIVE GRILLE	Black perforated steel with scrim cloth backing
CONNECTORS	2 x NL4 type
PIN CONNECTIONS (INPUT)	1+/-
PIN CONNECTIONS (LINK)	1+/- to 1+/-
FITTINGS	19 x M8 inserts, pole-mount socket, 1 x bar handle
DIMENSIONS	(W) 324mm x (H) 522mm x (D) 289mm (W) 12.8ins x (H) 20.6ins x (D) 11.4ins
WEIGHT	14kg (30.9lbs)
ACCESSORIES	Wall bracket, eyebolts

Notes

- (1) Measured on-axis in half (2pi) space at 2 metres, then referred to 1 metre.
- (2) AES Standard ANSI S4.26-1984.
- (3) Measured in half (2pi) space at 2 metres with 1 watt input, using band limited pink noise, then referred to 1 metre.
- (4) Measured in half (2pi) space at 2 metres using band limited pink noise, then referred to 1 metre.
- (5) Measured on-axis in open (4pi) space at 2 metres, then referred to 1 metre.
- (6) Measured in open (4pi) space at 2 metres with 1 watt input, using band limited pink noise, then referred to 1 metre.
- (7) Measured in open (4pi) space at 2 metres using band limited pink noise, then referred to 1 metre.
- (8) Measured in open (4pi) space at 2 metres with 2.83v input, using band limited pink noise, then referred to 1 metre.
- (9) Calculated at 1 metre.
- (10) Measured in half (2pi) space at 2 metres with 2.83V input, using band limited pink noise, then referred to 1 metre.

Trade Descriptions Act

Due to Martin Audio's policy of continuing improvement, we reserve the right to alter these specifications without prior notice. Martin Audio is committed to refining state of the art sound reinforcement, combining in-depth product and field applications research with advanced manufacturing techniques. Every Martin Audio product is built to the highest manufacturing standards and rigorously tested to ensure that it meets the performance criteria specified in the design.

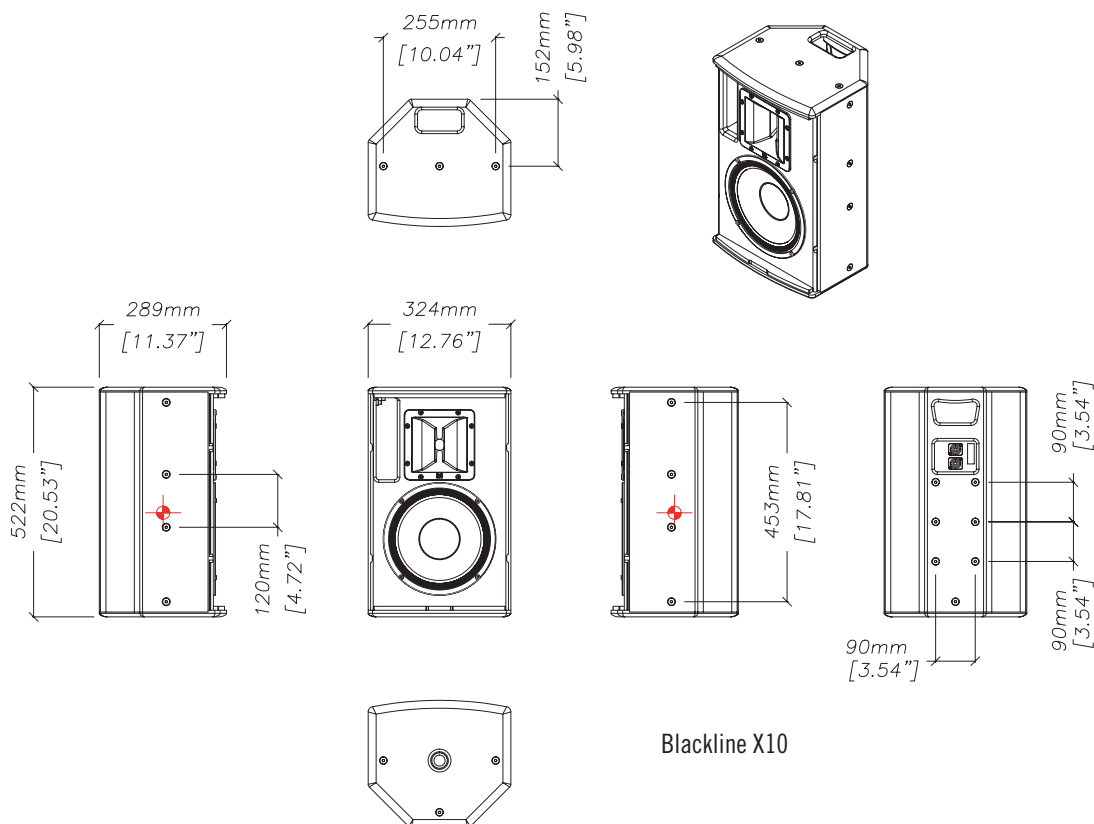

Blackline X10

Martin Audio Ltd
Century Point, Halifax Road, High Wycombe
Buckinghamshire HP12 3SL, England

Telephone: +44 (0) 1494 535 312
Facsimile: +44 (0) 1494 438 669
Email: info@martin-audio.com

