



# NLB 60E



- ▶ **Ethernet to NomadLink® Bridge** – Provides an Ethernet link between a PC and a NomadLink® network for monitoring and control of up to 60 NomadLink-ready amplifiers per NLB 60E
- ▶ **Network power on/off** – Dedicated switches control power on/off for all amplifiers connected to the network
- ▶ **General Purpose Inputs (GPIs)** – Three GPIs each individually programmable for external triggering of power on/off or mute on all amplifiers
- ▶ **Bright LED display** – Ultra-bright 16x2 character display for easy reading in high ambient light
- ▶ **Keypad user interface** – Six momentary keys access amplifier status information, parameter selection, and data entry.
- ▶ **Fault Indication** – Bright red LED signals a fault condition, with detailed information accessible on the 16x2 display or connected PC
- ▶ **Phantom powering for network** – Amplifiers stay online with zero power consumption, remaining ready for immediate use
- ▶ **Front and rear Ethernet ports** – Rear port for permanent connection, with parallel front port for quick maintenance access
- ▶ **Front-panel password lockout** – Prevents unauthorized operation or reprogramming

## A network bridge and dedicated user interface

The NLB 60E NomadLink® Bridge & Network Controller serves as the keystone component in all networked applications for Lab.gruppen's NomadLink-ready power amplifiers. As a stand alone unit, the NLB 60E provides facilities for monitoring amplifier parameters, detecting fault conditions, and controlling key functions (power on/off sequencing and mute) over a proprietary NomadLink® network comprising up to 60 amplifiers.

Connecting a PC running DeviceControl software to the NLB 60E greatly enhances the control and monitoring functions available through NomadLink®. In this configuration, the NLB 60E operates as a network bridge, relaying amplifier status and operation information to the host PC over a standard TCP/IP Ethernet link. This Ethernet connection also transmits control configuration data generated by the DeviceControl application to the NLB 60E for dissemination to amplifiers on the NomadLink® network. A secure connection feature, with multiple levels of password protection, is also available within DeviceControl to prevent unauthorized access to the amplifier network.

Configuring a NomadLink® network is quick and straightforward. A large rack of amplifiers can be networked in minutes simply by clicking in Cat-5 cables and forming a daisy-chain loop beginning and ending with the NLB 60E. Cables can be terminated with either standard RJ45 connectors or impact-resistant Neutrik Ethercon versions as appropriate (amplifier model dependent). Phantom power for the amplifier network modules is supplied by the NLB 60E, allowing all amplifiers to remain online in standby mode with zero power consumption. To accommodate remote amplifier locations, NomadLink® allows up to 300 meters between any two devices, and a total closed-loop subnet length of up to 700 meters.

The NLB 60E also incorporates three GPIs (General Purpose Inputs): one voltage sensing and two contact closure. The GPIs can be configured to respond to remote equipment such as alarm systems and external power-up sequencers. As an alternative, internal power-up sequencing is included in the NLB 60E.

The front-panel interface provides convenient access to amplifier status information and critical control functions. Dedicated power on and off switches control all amplifiers on the network. Other functions and comprehensive status information are accessible by intuitive navigation of a menu tree, with all information clearly visible on the ultra-bright 16x2 character LED display.



## Network Configurations using the NLB 60E

The possible NomadLink® network configurations range from a single amplifier up to complex, TCP/IP-based networks comprising as many as 960 amplifiers. The building block for all Lab.gruppen amplifier networks is the single NomadLink® subnet.

This subnet is formed by connecting a number of amplifiers – from 1 to 60 – to an NLB 60E. Optionally a Windows PC can be operated on the NLB 60E Ethernet connection, running DeviceControl software for extensive control and monitoring of the network performance.

### Network with one NLB 60E and DeviceControl

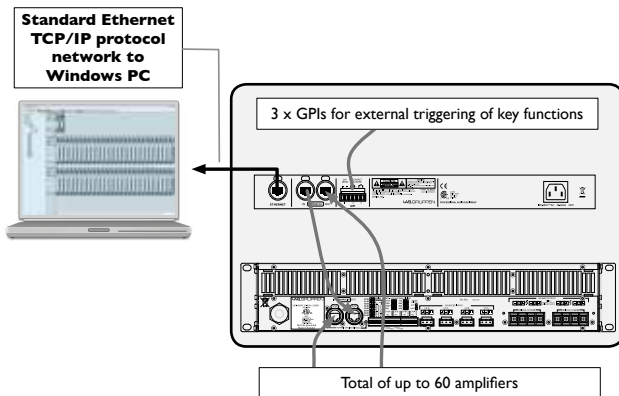

### Multiple NomadLink® subnets connected to Ethernet LAN and controlled from single PC (up to 16 subnet's possible)

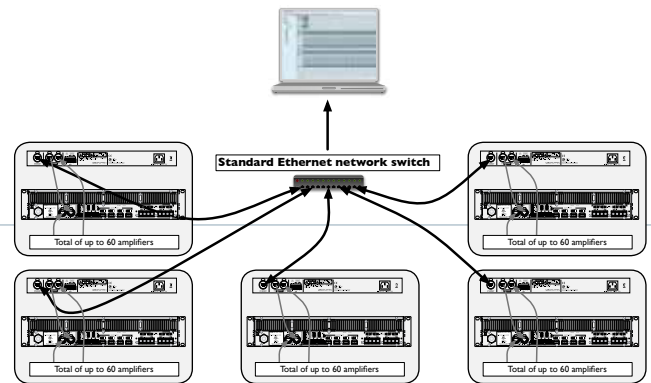

## Specifications NLB 60E

<b>Network connectors</b>	
NomadLink® Out	EtherCon housed RJ45
NomadLink® In	EtherCon housed RJ45
Ethernet rear-panel	EtherCon housed RJ45
Ethernet front-panel	Standard RJ45
<b>General Purpose Input (GPI)</b>	
1 x Voltage sensing input (10 V is the trigger level)	2-pole Phoenix
2 x Contact closure input	2-pole Phoenix
<b>Front panel I/c indicators</b>	
Front operation locked (Yellow); Fault warning (Red); Subnet muted (Red); NomadLink® network connected/activity (Blue); Ethernet connected (Orange); Ethernet activity (Yellow).	
<b>Display</b>	2 x 16 character; white text on blue background
<b>Navigation and adjust keys</b>	Yes, x 6
<b>Subnet power on/off keys</b>	Yes, x 2
<b>Mains power supply</b>	100 to 240 VAC, 50 to 60 Hz (auto-select)
<b>Power consumption</b>	< 35 W
<b>Dimensions (W x H x D)</b>	483 x 44 x 208 mm (19 x 1 U x 8.2")
<b>Weight</b>	2.25 kg (5 lbs)
<b>Finish</b>	Black anodized aluminium front and painted steel chassis

All specifications are subject to change without notice.

**LAB.GRUPPEN**

WWW.LABGRUPPEN.COM

Item no. TDS-NLB60E\_V3 - 02.12.2015