

# VC520 Pro3

## User Manual



## Federal Communications Commission Statement

NOTE: This equipment has been tested and found to comply with the limits for a Class A digital device, pursuant to part 15 of the FCC Rules. These limits are designed to provide reasonable protection against harmful interference when the equipment is operated in a commercial environment. This equipment generates, uses, and can radiate radiofrequency energy and, if not installed and used in accordance with the instruction manual, may cause harmful interference to radio communications. Operation of this equipment in a residential area is likely to cause harmful interference in which case the user will be required to correct the interference at his own expense.

FCC Caution: Any changes or modifications not expressly approved by the party responsible for compliance could void the user's authority to operate this equipment.

This device complies with part 15 of the FCC Rules.

Operation is subject to the following two conditions:

- (1) This device may not cause harmful interference, and
- (2) this device must accept any interference received, including interference that may cause undesired operation.

### Warning:

This is a class A product. In a domestic environment this product may cause radio interference in which case the user may be required to take adequate measures.

This Class A digital apparatus complies with Canadian ICES-003. Cet appareil numérique de la classe A est conforme à la norme NMB-003 du Canada.

この装置は、クラス A 機器です。この装置を住宅環境で使用すると電波妨害を引き起こすことがあります。この場合には使用者が適切な対策を講ずるよう要求されることがあります。 **VCCI-A**

사 용 자 안 내 문	
이 기기는 업무용 환경에서 사용할 목적으로 적합성평가를 받은 기기로서 가정용 환경에서 사용하는 경우 전자파간섭의 우려가 있습니다.	
※ 사용자 안내문은 "업무용 방송통신기자재"에만 적용됩니다.	

기종별	사용자안내문
A 급 기기 (업무용 방송통신기자재)	이 기기는 업무용(A 급) 전자파적합기기로서 판매자 또는 사용자는 이 점을 주의하시기 바라며, 가정외의 지역에서 사용하는 것을 목적으로 합니다.

## **DISCLAIMER**

No warranty or representation, either expressed or implied, is made with respect to the contents of this documentation, its quality, performance, merchantability, or fitness for a particular purpose. Information presented in this documentation has been carefully checked for reliability; however, no responsibility is assumed for inaccuracies. The information contained in this documentation is subject to change without notice.

In no event will AVer Information Inc. be liable for direct, indirect, special, incidental, or consequential damages arising out of the use or inability to use this product or documentation, even if advised of the possibility of such damages.

## **TRADEMARKS**

“AVer” is a trademark owned by AVer Information Inc. Other trademarks used herein for description purpose only belong to each of their companies.

## **COPYRIGHT**

©2023 AVer Information Inc. All rights reserved. | August 10, 2023

All rights of this object belong to AVer Information Inc. Reproduced or transmitted in any form or by any means without the prior written permission of AVer Information Inc. is prohibited. All information or specifications are subject to change without prior notice.

## **NOTICE**

Specifications Are Subject to Change without Prior Notice. The Information Contained Herein Is to Be Considered for Reference Only.

## WARNING

- To reduce risk of fire or electric shock, do not expose this appliance to rain or moisture. Warranty will be void if any unauthorized modifications are done to the product.
- Do not drop the camera or subject it to physical shock.
- Use correct power supply voltage to avoid damaging camera.
- Do not place the camera where the cord can be stepped on as this may result in fraying or damage to the lead or the plug.
- Hold the bottom of the camera with both hands to move the camera. Do not grab the lens or lens holder to move the camera.

### Remote Control Battery Safety Information

- Store batteries in a cool and dry place.
- Do not throw away used batteries in the trash. Properly dispose of used batteries through specially approved disposal methods.
- Remove the batteries if they are not in use for long periods of time. Battery leakage and corrosion can damage the remote control. Dispose of batteries safely and through approved disposal methods.
- Do not use old batteries with new batteries.
- Do not mix and use different types of batteries: alkaline, standard (carbon-zinc) or rechargeable (nickel-cadmium).
- Do not dispose of batteries in a fire.
- Do not attempt to short-circuit the battery terminals.

## CAUTION

- Risk of explosion if battery is replaced by an incorrect type.
- Dispose of used batteries in a safe and proper manner.

### 遥控器电池安全信息

- 请将电池存放在凉爽与干燥的位置。
- 不要将电量用尽的电池弃置在家庭废弃物中。请将电池弃置在特定回收处,或送回原购买的商店。
- 如果长时间不使用电池,请将其取出。电池漏液与腐蚀可能会损坏遥控器,请以安全方式弃置电池。
- 不可混用新旧电池。
- 不可混用不同类型的电池:碱性、标准(碳锌)或可充电(镍镉)电池。
- 不可将电池弃置于火源中。
- 请勿尝试让电池端子短路。

## More Help

For FAQs, technical support, software and user manual download, please visit:

### Headquarters

Download Center: <https://www.aver.com/download-center>

Technical Support: <https://www.aver.com/technical-support>

### USA Branch office

Download Center: <https://www.averusa.com/business/support/>

Technical Support: <https://averusa.force.com/support/s/contactsupport>

### Europe Branch office

Download Center: <https://www.avereurope.com/download-center>

Technical Support: <https://www.avereurope.com/technical-support>

## Contact Information

### Headquarters

AVer Information Inc.

<https://www.aver.com>

8F, No.157, Da-An Rd., Tucheng Dist., New Taipei City 23673, Taiwan

Tel: +886 (2) 2269 8535

### USA Branch office

AVer Information Inc., Americas

<https://www.averusa.com>

668 Mission Ct., Fremont, CA 94539, USA

Tel: +1 (408) 263 3828

Toll-free: +1 (877) 528 7824

Technical support: [support.usa@aver.com](mailto:support.usa@aver.com)

### Europe Branch office

AVer Information Europe B.V.

<https://www.avereurope.com>

Westblaak 134, 3012 KM, Rotterdam, The Netherlands

Tel: +31 (0) 10 7600 550

Technical support: [eu.rma@aver.com](mailto:eu.rma@aver.com)

### Japan Branch Office

アバー・インフォメーション株式会社

<https://jp.aver.com>

〒160-0023 日本東京都新宿区西新宿 3-2-26 立花新宿ビル 7 階

Tel: +81 (0) 3 5989 0290

テクニカル・サポート: <https://jp.aver.com/technical-support>

### Vietnam Branch Office

Công ty TNHH AVer Information (Việt Nam)

Tầng 5, 596 Nguyễn Đình Chiểu, P.3, Quận 3,

Thành phố Hồ Chí Minh 700000, Việt Nam

Tel: +84 (0)28 22 539 211

# Contents

<b>Package Contents</b> .....	<b>1</b>
Package Contents .....	1
<b>Product Introduction</b> .....	<b>2</b>
Overview .....	2
Camera LED Indicator .....	2
Speakerphone LED Indicator .....	3
Expansion Speakerphone/Microphone Connection .....	4
Phone in Connection .....	5
Pan and Tilt Angle .....	5
Audio Signal Receive Range .....	6
Remote Control .....	7
<b>Installation</b> .....	<b>9</b>
Device Connection .....	9
RS-232 Connection .....	11
Computer/Keyboard Controller and Camera Connection .....	12
Camera Cascade Connection .....	15
Wall Mount Installation .....	17
<b>Set up the Camera</b> .....	<b>20</b>
Make a Video Call .....	20
Connect with PTZApp 2 .....	20
Connect through the Browser .....	20
Use the AVer IPcam Utility to Find the Camera .....	20
<b>Web Interface</b> .....	<b>22</b>
First Time Login .....	22
Main Screen Overview .....	23
PTZ Control .....	24
Setting .....	25
Camera Setting .....	25

Image Settings .....	28
RS-232 Settings .....	31
Video Format Settings .....	32
RTSP .....	34
RTMP .....	35
Network Settings .....	36
System Settings .....	37
Audio Settings .....	39
<b>EZLive .....</b>	<b>41</b>
Introduction .....	41

# Package Contents

## Package Contents



Camera Unit

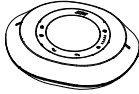

Speakerphone Unit



Remote Control

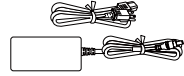

Power Adapter & Power Cord\*

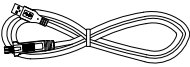

USB 2.0 Type-B to Type-A Cable (5m)

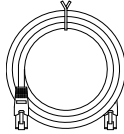

Speakerphone Cable (10m)

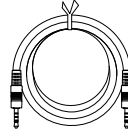

3.5 mm Audio Cable (0.9m)

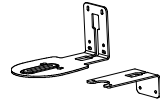

L-Mount Brackets



M4 x8mm Screw (x2)



1/4"-20 L=7.5mm Screw (x2)

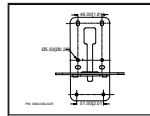

Drilling Paper

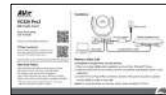

QR Code Card

\*The power cord will vary depending on the standard power outlet of the country where it is sold.



# Product Introduction

## Overview

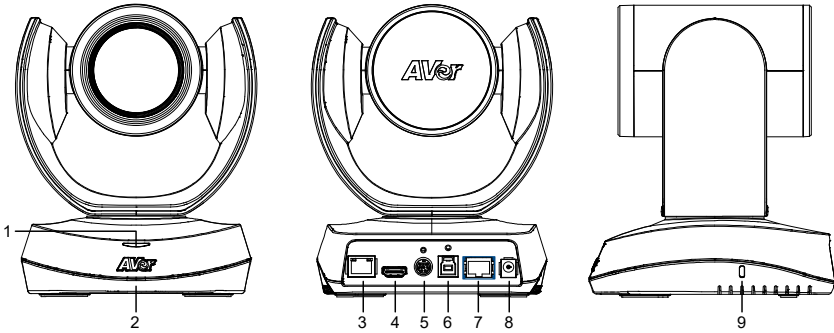

- |   |                          |   |                                |
|---|--------------------------|---|--------------------------------|
| 1 | Status LED               | 6 | USB3.1 Type-B Port             |
| 2 | IR Sensor                | 7 | Speakerphone Port (Blue cable) |
| 3 | Ethernet Port            | 8 | DC 12V Power Jack              |
| 4 | HDMI Output Port (to TV) | 9 | Kensington Lock                |
| 5 | RS-232 In/Out Port       |   |                                |

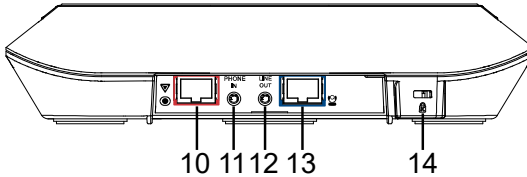

- |    |   |    |                          |
|----|---|----|--------------------------|
| 10 | Speakerphone Port<br>(Red Cable, for extended<br>speakerphone and<br>microphone connection) | 11 | Phone In Port            |
|    |   | 12 | Line Out Port            |
|    |   | 13 | Camera Port (Blue Cable) |
|    |   | 14 | Kensington Lock          |

## Camera LED Indicator

**Power on:** Blink blue once





**Start-up:** Solid red

**Video mute:** Solid orange

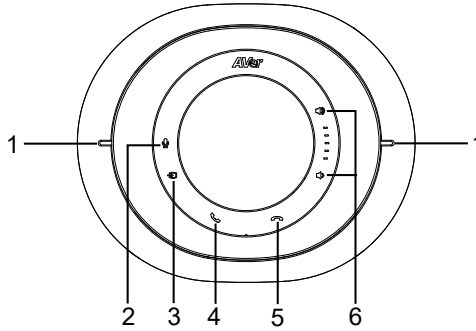
**Video on:** Solid blue

# Speakerphone LED Indicator



No.	LED Indicator	Status
1. LED Status Indicator	Solid red, then blink white once	Start-up
	Solid blue	Power on
	Solid orange	Idle
	Solid red	Mic mute (in meeting)
	Solid blue	Mic unmute (in meeting)
2. Mute/Unmute 	Solid red	Touch to mute the microphone.
	Solid blue	Touch to unmute the microphone.
3. Phone input 	Solid blue	Connects with external device
	Solid white	Temporarily disconnects the connection with the device
	Off	No connection with external devices
4. Make/Answer call 	Solid green	Touch to answer the incoming call.
5. Hang up call 	Solid red	Touch to hang up the call.
6. Volume up/down 	Solid white	Adjust the volume up and down. When adjusting the volume up and down, the volume LED indicator will light up in blue.
	Solid red	Touch the volume down for 1 second to mute the speaker out, the volume down button will light up in red.

# Expansion Speakerphone/Microphone Connection

There are 2 types of expansion solutions that can be extended from the **VC520 Pro3** speakerphone. Please purchase the expansion speakerphone and/or microphone directly from AVer or an AVer reseller.

## Expansion Speakerphone Requirements:



- **VC520 Pro3 Firmware version:** 0.0.9800.08 or later
- **FONE540 Firmware version:** 7000.44 or later

## [Notes]

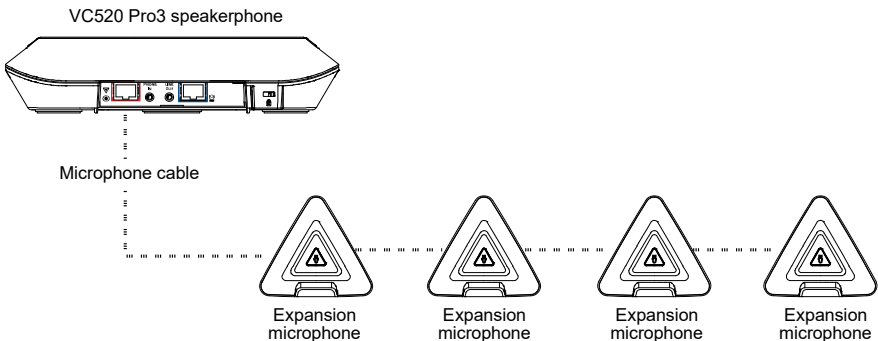
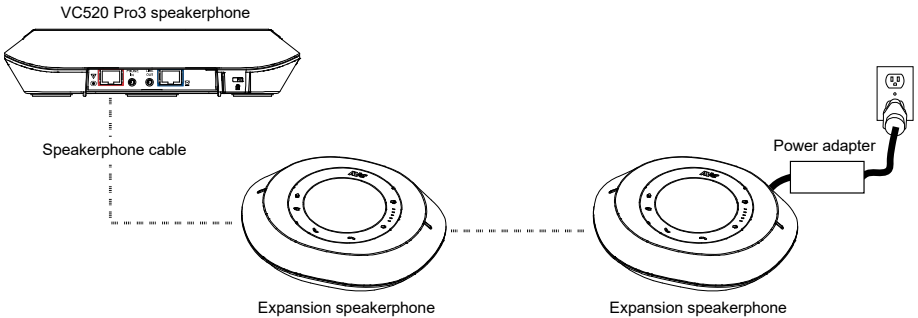
- The **VC520 Pro3** can support **up to 2** expansion speakerphones, however, the daisy-chain expansion cable cannot exceed over 40m in total.
- Please connect the expansion speakerphone to the power supply when daisy-chaining over 20m.
- Please connect the expansion speakerphone to the power supply when upgrading the firmware.
- The expansion speakerphone cannot be used as the main speakerphone; it can only be used with the **VC520 Pro3**.
- The speakerphone/microphone cables will be included in the package contents when the user purchases the expansion speakerphone/microphone.



## Phone in Connection

You can connect a mobile phone to the Phone in port on the speakerphone as a hands-free speaker. When the device connects with the speakerphone, the  icon will light up in blue. Touching the  icon will temporarily disconnect the connection of the device with the speakerphone; touching the  icon again will resume the connection.

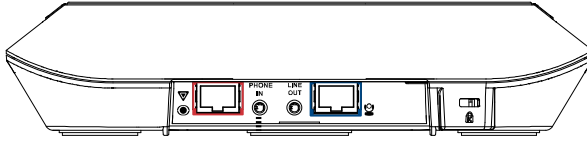

3.5mm audio cable

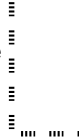

Mobile phone

## Pan and Tilt Angle

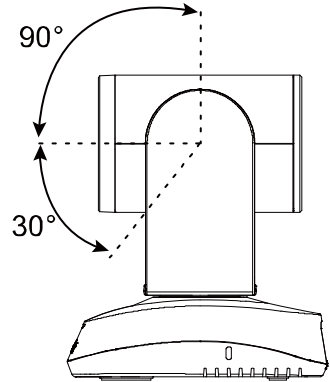
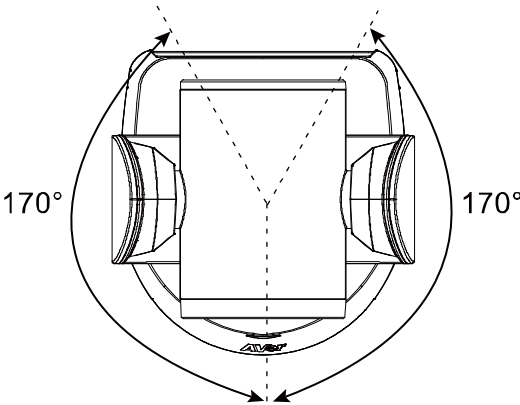

## Audio Signal Receive Range

The best distance for the speakerphone to receive audio signal is within 7.5ft (2.3m) in radius. When connecting two or more speakerphones, the distance between the speakerphones must be 9ft (2.7m).

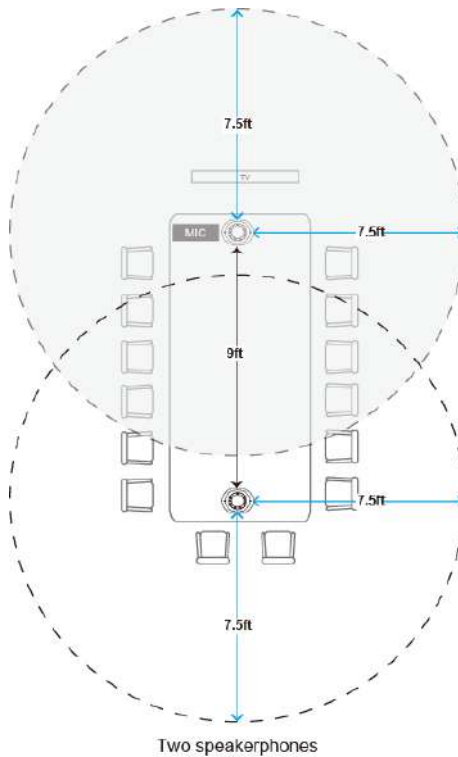
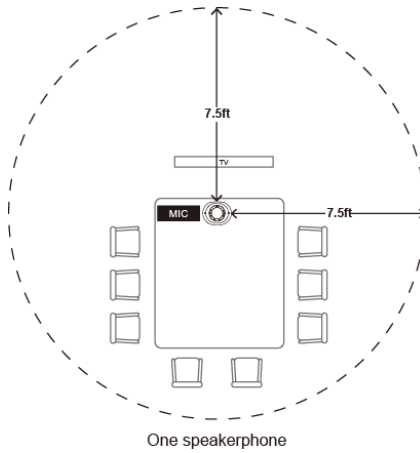

# Remote Control

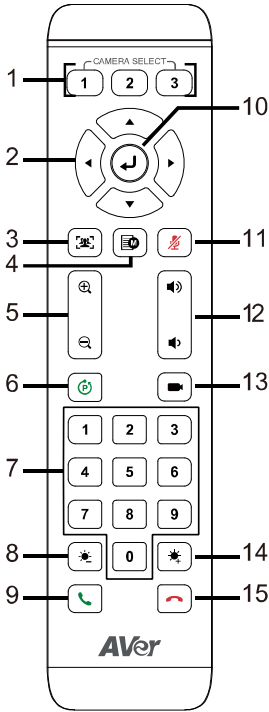

Name	Function
1 Camera Select	Select a camera to operate. Specify a number in the PTZApp 2 or web interface: <b>Settings &gt; Camera Binding</b> . All three selections can by default operate the camera.
2 Direction	Press once for incremental movement or press and hold for continuous pan or tilt.
3 SmartFrame	Short press to fit all participants. Long press (1 second) to switch among modes. For more details about the tracking modes, refer to < <a href="#">Camera Settings</a> >--Tracking Modes.
4 OSD Menu	Call out On Screen Display menu.
5 Zoom In/Zoom Out	Press to zoom in and out.
6 Preset	The Preset button on the remote serves 2 functions: <ul style="list-style-type: none"> <li>● <b>Save a Preset:</b> <ol style="list-style-type: none"> <li>1. Move the camera to desired position.</li> <li>2. Press and hold the preset button until you see the saving message on the screen.</li> <li>3. Select a preset position button from 0-9 to save the current camera position. Repeat steps if needed.</li> </ol> </li> <li>● <b>Load a Preset:</b> <p>Press the <b>Preset</b> button and preset number button to load a saved camera position. Repeat steps if needed.</p> </li> </ul>
7 Preset Position/Number Buttons	Press the <b>Preset</b> button first, and press the number buttons to move the camera to the saved position. <p><b>[Tips]</b></p> <ul style="list-style-type: none"> <li>● Press and hold the number button “1” for 1 second to turn on or off the WDR function.</li> <li>● Press and hold the number button</li> </ul>

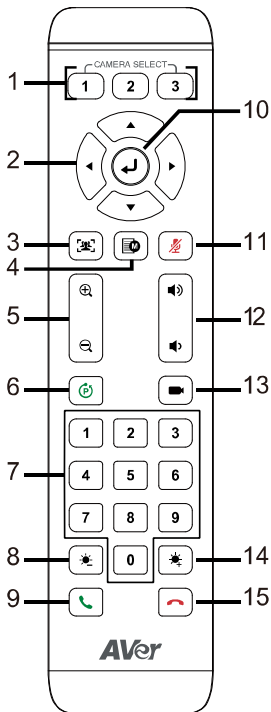

		<p>“ 5 ” for 1 second to turn on or off the <b>SmartFrame</b> function.</p> <ul style="list-style-type: none"> <li>● Press and hold the number button “ 8 ” for 1 second to enable or disable RTMP streaming function.</li> <li>● Press and hold the number button “ 9 ” for 1 second to force camera to enter sleep mode. This will end any video streaming. To wake up the camera, press the button or any directional button for 1 second. This mode is not functional while USB streaming is on.</li> </ul>
8	Brightness -	Decrease the brightness.
9	Call/Answer	Answer a call or start a call.
10	Enter	Confirm selection.
11	Mute/Unmute Speakerphone	Mute/Unmute the speakerphone.
12	Volume Up/Down	Volume up or down.
13	Preset Hot Key	Press to move the camera to the preset position you have set.
14	Brightness +	Increase the brightness.
15	Hang Up	End the call.

# Installation

## Device Connection

1. Connect the camera to the power outlet.

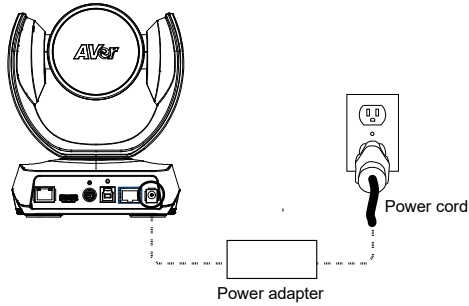

- 
2. Connect the camera to the speakerphone with the included compatible cable.

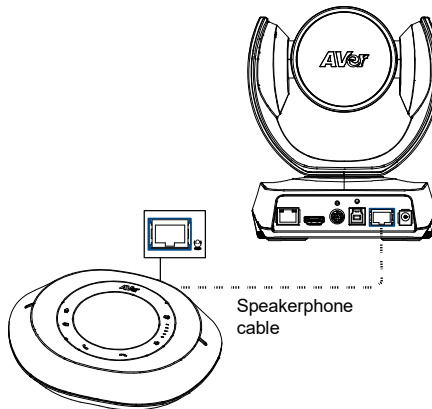

- 
3. Connect other necessary cables.

Secure the USB and RS-232 cables with attached screws. (RS-232 cable is an optional accessory; please purchase from AVer.)

Make sure the cables are well connected to the connector on the camera before securing the cable.



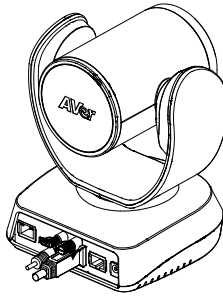

4. Connect the camera to the computer/laptop using the included compatible cable.

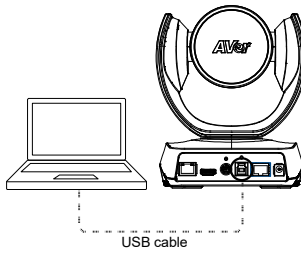

**[Notes]**

- Use the USB 2.0 cable included in the package.
- **VC520 Pro3** has the USB 3.1 port which is USB 2.0 compatible.

Maximum resolution/fps for USB 2.0 and USB 3.1 ports are shown below.

	M-JPEG/fps	YUV/fps
USB 2.0	1080@60 fps	720p@10 fps 480p@30 fps
USB 3.1	1080p@60 fps	1080p@30 fps

# RS-232 Connection

## ■ Camera RS-232 Port Pin Definition

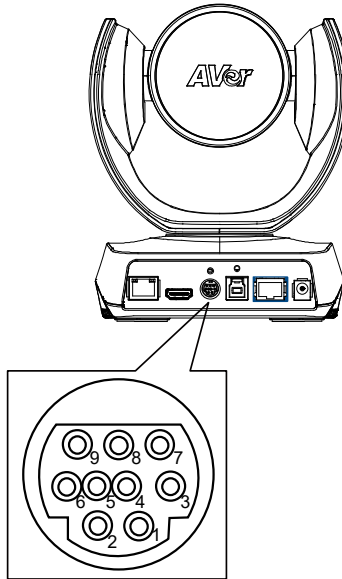

Function	Mini DIN9 PIN #	I/O Type	Signal	Description
VISCA IN	1	Output	DTR	Data Terminal Ready
	2	Input	DSR	Data Set Ready
	3	Output	TXD	Transmit Data
	6	Input	RXD	Receiver Data
VISCA OUT	7	Output	DTR	Data Terminal Ready
	4	Input	DSR	Data Set Ready
	8	Output	TXD	Transmit Data
	9	Input	RXD	Receiver Data
	5	---	---	Not connect

# Computer/Keyboard Controller and Camera Connection

## Direct Connection

If you do not have an AVer RS-232 adapter cable, please refer to the pin connection shown below.

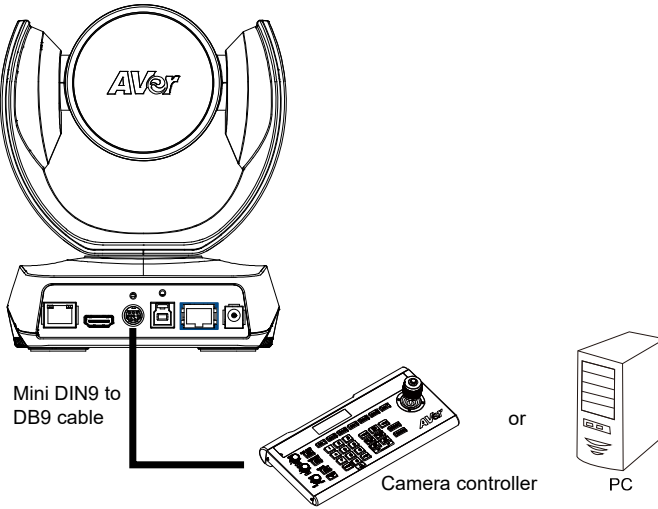

Camera (Mini DIN9)	Camera controller or PC (DB9)
1. DTR (IN)	1. DCD
2. DSR (IN)	2. RXD
3. TXD (IN)	3. TXD
6. RXD (IN)	4. DTR
7. DTR (OUT)	5. GND
4. DSR (OUT)	6. DSR
8. TXD (OUT)	7. RTS
9. RXD (OUT)	8. CTX
	9. RI

Use the RS-232 mini DIN9 to mini DIN8 cable (Sold separately. Please purchase from AVer.).

You can purchase AVer RS-232 min DIN9 to mini DIN8 adapter cable\* to connect with Computer or keyboard/controller.

**[Notes]**

- RS-232 mini DIN9 to mini DIN8 cable (PN: 064AOTHERCDC)
- Mini DIN8 to D-Sub9 (DB9) cable (PN: 064AOTHERBPK) is an optional item.

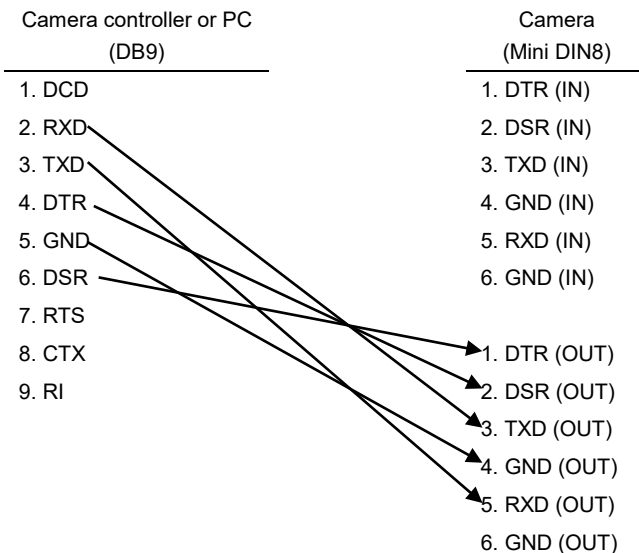
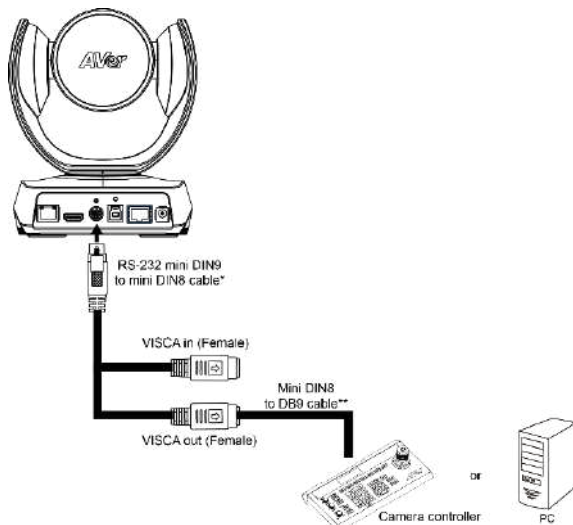

## RS-232 mini DIN9 to mini DIN8 Cable Pin Definition

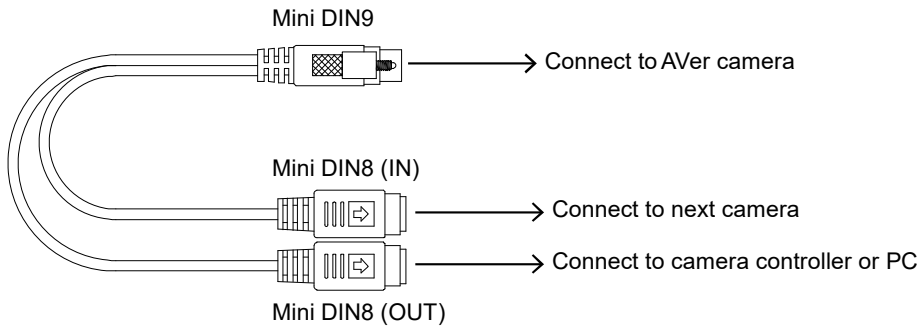

## Mini DIN8 Pin Definition

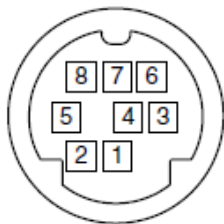

No.	Pin
1	DTR
2	DSR
3	TXD
4	GND
5	RXD
6	GND
7	NC
8	NC

# Camera Cascade Connection

## Direct Connection

If you don't have an AVer RS-232 adaptor cable, please refer to the pin connection shown below for cascading cameras.

You can connect up to 7 cameras.

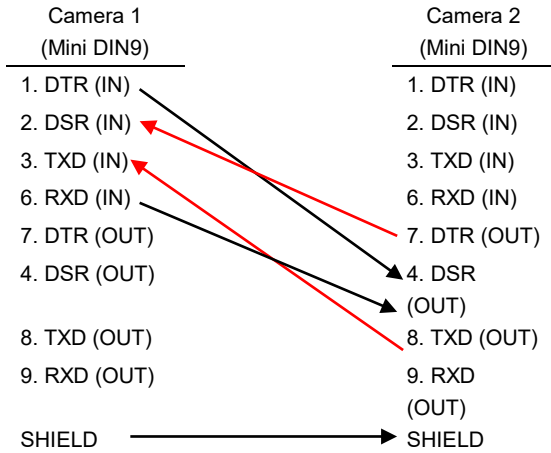
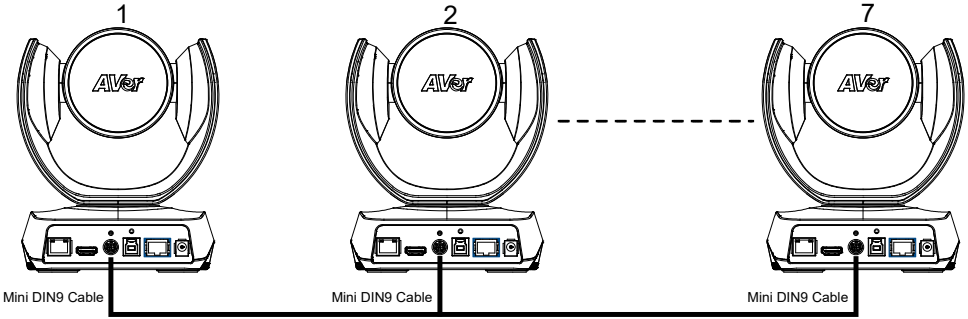

## Use the RS-232 mini DIN9 to mini DIN8 cable

You can connect up to 7 cameras.

To facilitate cascade connection, you can purchase an AVer RS-232 adapter cable.

Connect camera with AVer mini DIN9 to mini DIN8 adapter cable. Connect the mini DIN8 female side to male mini DIN8 Visca cable (Users have to buy it in the market) and then connect AVer mini DIN9 to mini DIN8 adapter cable again to connect to next camera.

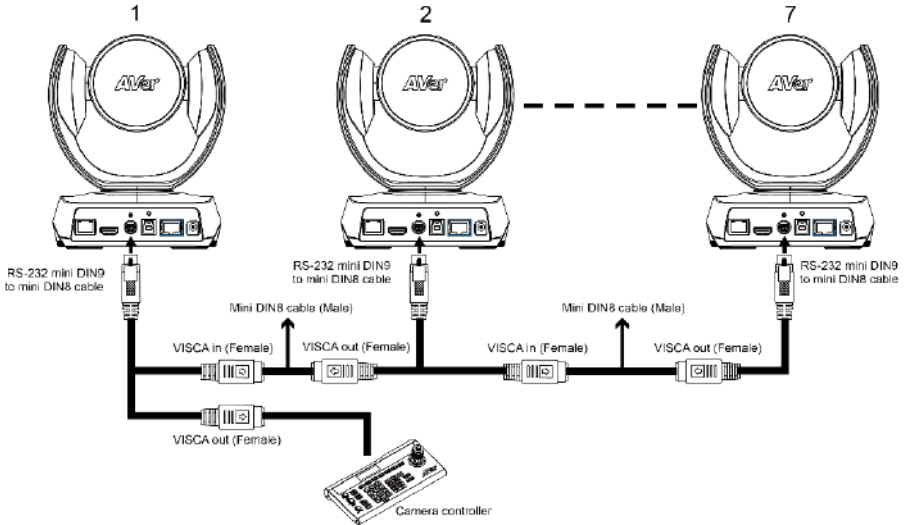

Camera 1 (Mini DIN8)	Camera 2 (Mini DIN8)
1. DTR (IN)	1. DTR (IN)
2. DSR (IN)	2. DST (IN)
3. TXD (IN)	3. TXD (IN)
4. GND (IN)	4. GND (IN)
5. RXD (IN)	5. RXD (IN)
6. GND (IN)	6. GND (IN)
1. DTR (OUT)	1. DTR (OUT)
2. DSR (OUT)	2. DST (OUT)
3. TXD (OUT)	3. TXD (OUT)
4. GND (OUT)	4. GND (OUT)
5. RXD (OUT)	5. RXD (OUT)
6. GND (OUT)	6. GND (OUT)

## Wall Mount Installation

1. Use the drilling paper included in the package to drill holes on the place where you want to mount the camera.

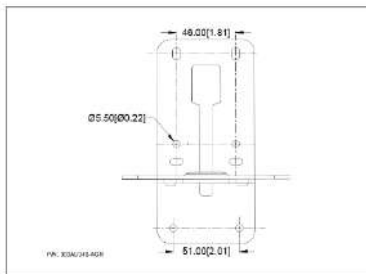

2. Use the screws (not included) to secure the L-mount bracket **A** on the wall.

- **Screws:**

**For Cement wall:** M4 x20mm self-tapping screws (x4) + Plastic conical anchor

**For Wooden wall:** M4 x20mm self-tapping screws (x4)

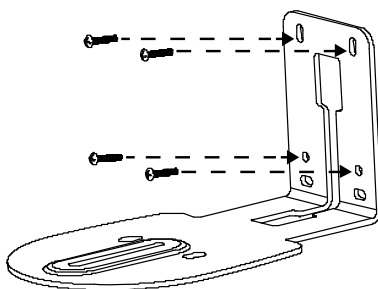



3. Then, assemble the L-mount brackets **A** + **B** with screws (included in package).

**Screws:**  M4 x8mm (x2)

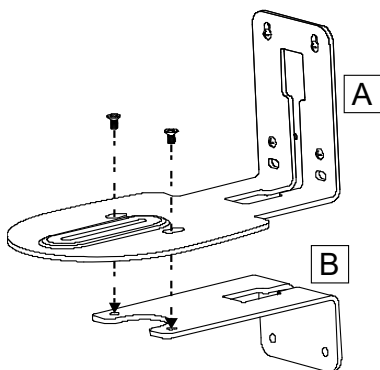

4. After assembling the L-mount brackets, use the screws (not included) to secure the L-mount bracket **B** on the wall.

● **Screws:**

**For Cement wall:** M4 x20mm self-tapping screws (x2) + Plastic conical anchor

**For Wooden wall:** M4 x20mm self-tapping screws (x2)

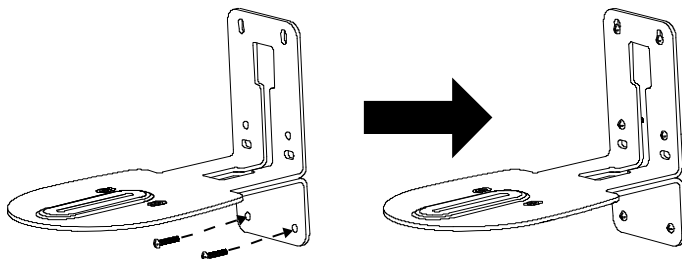

5. Pass the cables through the hole on the L-mount brackets and connect the cables to the according connection ports.

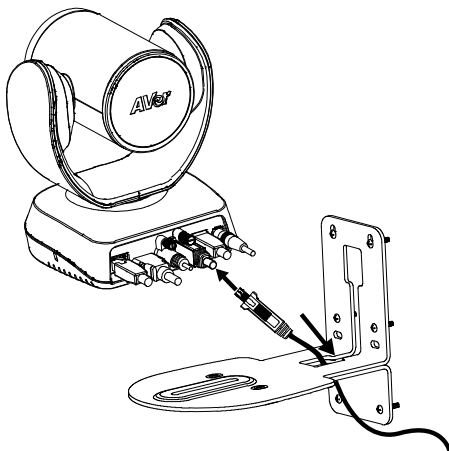

6. Use the remaining screws (included in package) to secure the camera on the L-mount brackets.

**Screws:**  1/4"-20 L=7.5mm (x2)

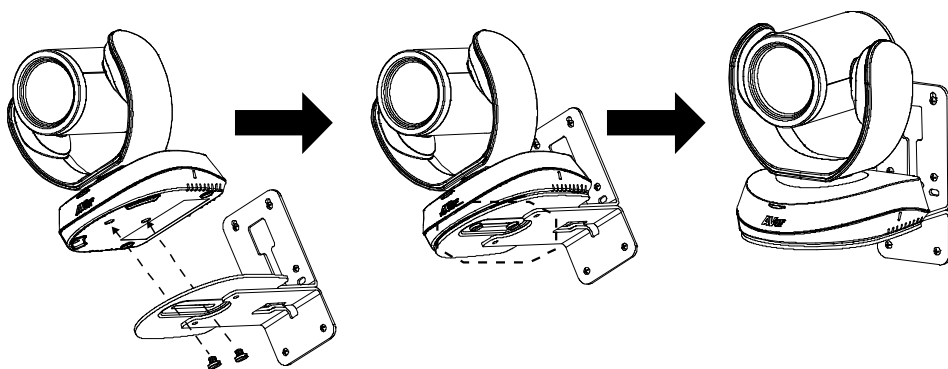

## Set up the Camera

**VC520 Pro3** is a plug-and-play conference camera. You may use the USB cable to connect or log in to the web UI with the Ethernet port.

### Make a Video Call

1. Make sure all devices (**VC520 Pro3**, speakerphone and PC/laptop) are well connected and power is on.
2. Run video application (Zoom, Microsoft® Teams, Skype for Business, Skype, Google Meet, Intel® Unite™, RingCentral, BlueJeans, V-Cube, LiveOn, CyberLink U Meeting®, TrueConf, Adobe Connect, Cisco WebEx®, Fuze, GoToMeeting™, Microsoft® Lync™, Vidyo, vMix, WebRTC, Wirecast, XSplit, etc.) on your PC or laptop.
3. Set the **VC520 Pro3** camera and speakerphone as the primary camera and speakerphone for your video application (refer to your video application user guide).

### Connect with PTZApp 2

You can use the USB cable to connect with your **VC520 Pro3** and utilize the **PTZApp 2** application to change the **VC520 Pro3** IP address setting, configure the parameters of the camera, set up AI tracking functions and more.

To download **PTZApp 2**, please go to <https://www.aver.com/download-center> (Headquarters & Europe) or <https://www.averusa.com/business/support/> (USA).

To set up **PTZApp 2** and connect with your **VC520 Pro3** device, please refer to **PTZApp 2 User Manual**:

<https://www.aver.com/Downloads/search?q=PTZApp%202>

### Connect through the Browser

**VC520 Pro3** has an Ethernet port for IP streaming and allows administrators to control remotely and set up the camera via internet access. **VC520 Pro3** also supports RTSP and RTMP functions. For more details, please contact our technical support.

### Use the AVer IPcam Utility to Find the Camera

1. Download **AVer IP Finder** from <https://www.aver.com/download-center> (Headquarters & Europe) or <https://www.averusa.com/business/support/> (USA) and launch the app.
2. Click **Search** to view all available devices on the screen.
3. Select **VC520 Pro3** from the list, and the camera IP address will be displayed.
4. Double-click on the camera IP address, and the system will redirect to the camera web interface.
5. Enter the default password: **aver4321** to log in to Web setup screen.

**[Notes]** To change camera IP address, you can select **DHCP** or **Static IP**.

The **DHCP** accesses the IP address from the local dynamic IP sever, while you can enter specific IP address for **Static IP**. Click **Apply** and enter password (the default password is **aver4321**) to apply the camera setting.

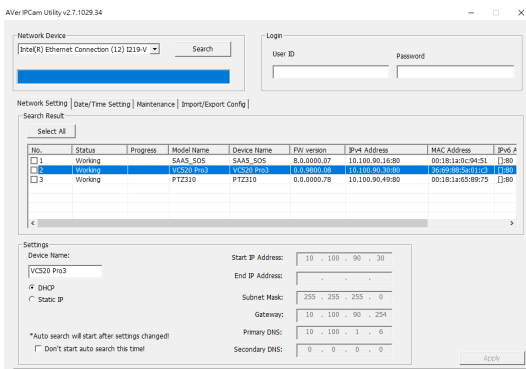

# Web Interface

**VC520 Pro3** supports Ethernet connection; you can enter the IP address into the web browser to connect to the camera for detail settings.

## First Time Login





1. Open the browser on your laptop/PC and enter the camera IP address.  
To find the camera IP address, please refer to [<Use the AVer IPcam Utility to Find the Camera>](#)
2. Enter the password at the login screen. The default password is **"aver4321"**.
3. Click **Login**.

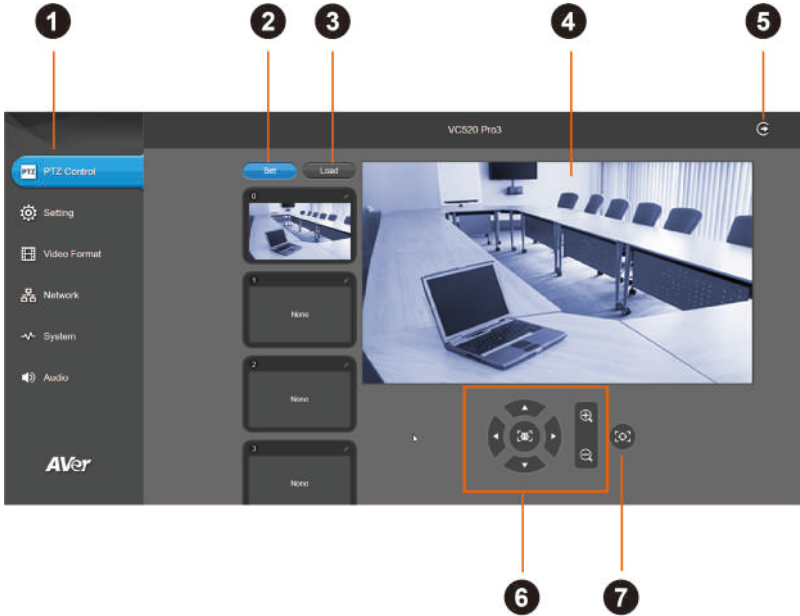

# Main Screen Overview

You can control the camera direction, configure camera settings, video format and more. The web will log out automatically when page is idle for more than 4 hours. The resolution of live screen is 840x480/10fps.



Item	Description
1 Menu	Click on the functions to view and configure the Web UI settings.
2 Set Preset Position	<ul style="list-style-type: none"> <li>Click the preset thumbnail to set preset camera position.</li> <li>Click the pencil icon  to rename the preset point.</li> <li>To reset the preset position, click on the preset thumbnail and adjust the camera position.</li> </ul>
3 Load Preset Position	Click on the preset thumbnail to switch to the preset position.
4 Live Screen	View camera live view from the screen.
5 Logout	Click to log out your account.
6 Control Panel	Click the buttons to adjust the camera directions, zoom in and zoom out. <ul style="list-style-type: none"> <li>: Directional buttons.</li> <li>: SmartFrame button.</li> <li>: Zoom in/out buttons.</li> </ul>
7 One Shot Focus	Click the button to focus on the subject.

# PTZ Control

You can control your camera, set up and reset up to 10 preset positions, edit preset position name and more.

## To set up a preset position:

1. In main screen, use ▲, ▼, ◀, ▶ and zoom in/out buttons to adjust the camera view to the desired position.
2. Select **Set** button above the preset thumbnails > click on the preset thumbnail to save the preset.

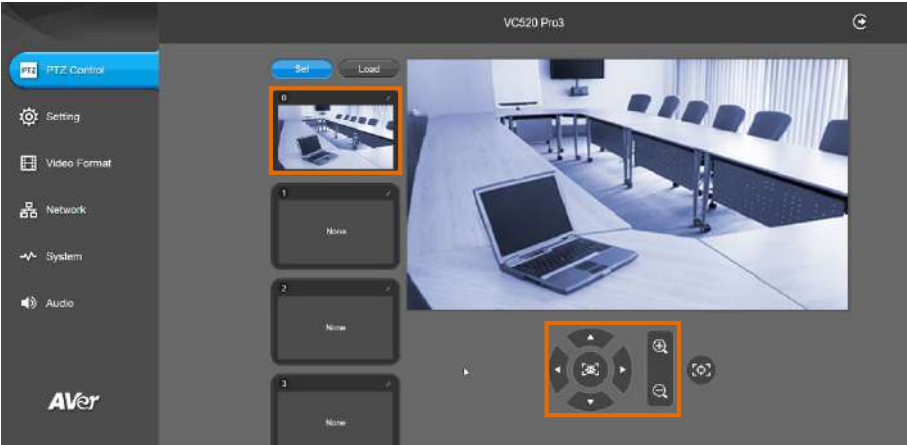



3. Select  icon to edit name of preset position. Click anywhere to save.
4. After setting up the preset positions, you can start performing the function. Select the **Load** button and then click on the preset numbers, the live screen will move to the preset screen view.



# Setting

You can configure **VC520 Pro3** settings including camera settings, image settings, RS-232 and more.

## Camera view window:

When entering the Setting page, there will be a minimized camera live view floating window. You can view the camera IP address, click on  to show and hide people count number, and click  to show and hide live streaming time. Click **X** to close the floating window.



# Camera Setting

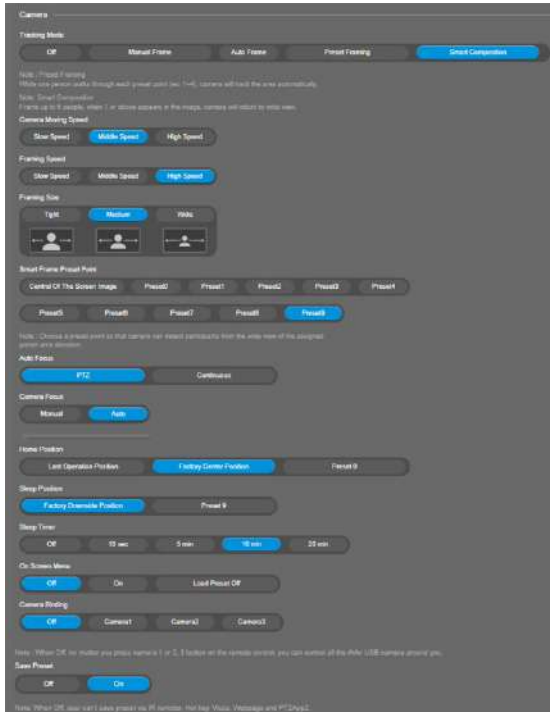



Item	Description	Options
Tracking Mode	Select a tracking mode or turn it off.	<ul style="list-style-type: none"> <li>● <b>Off:</b> Turn off the tracking mode.</li> <li>● <b>Manual Frame:</b> Click the <b>SmartFrame</b> button to fit all participants in the camera view.</li> <li>● <b>Auto Frame:</b> The camera will automatically track and frame all the detected participants on screen, and will keep stable until it detects any movements. You may adjust the <b>Framing Speed</b>.</li> <li>● <b>Preset Framing:</b> The camera will automatically follow and track the presenters when they enter the preconfigured preset points.</li> <li>● <b>Smart Composition:</b> The camera will automatically frame and zoom in on the detected participants in split screens.</li> </ul>
Camera Moving Speed	Select the camera moving speed when adjusting the camera direction.	<ul style="list-style-type: none"> <li>● Slow Speed</li> <li>● Middle Speed</li> <li>● High Speed</li> </ul>
Framing Speed	Adjust the framing speed when the camera detects no movements for 1~5 seconds.	<ul style="list-style-type: none"> <li>● <b>Slow Speed:</b> Frames the participants when the camera detects no movements for 5 seconds.</li> <li>● <b>Middle Speed:</b> Frames the participants when the camera detects no movements for 3 seconds (default).</li> <li>● <b>High Speed:</b> Frames the participants when the camera detects no movements for 1 seconds.</li> </ul>
Framing Size	Select a framing size that best suits your camera view.	<ul style="list-style-type: none"> <li>● <b>Tight:</b> Provides a close-up camera view (default).</li> <li>● <b>Medium:</b> Provides a medium camera view.</li> <li>● <b>Wide:</b> Provides a wide camera view.</li> </ul>
Smart Frame Preset Point	Select a position where camera frame and focus on the subject.	<ul style="list-style-type: none"> <li>● <b>Central Of The Screen Image:</b> The camera will frame and focus on the subject from the central of the screen image.</li> <li>● <b>Preset 0~9:</b> The camera will frame and focus on the subject from the select preset position.</li> </ul>
Auto Focus	Select an auto focus mode.	<ul style="list-style-type: none"> <li>● <b>PTZ:</b> The camera will adjust the focus after each move (Pan, tilt or zoom in/zoom out).</li> <li>● <b>Continuous:</b> The camera will keep focusing when it keeps still but the detected subject is moving.</li> </ul>

Camera Focus	Set auto/manual focus mode.	<ul style="list-style-type: none"> <li>● <b>Manual:</b> Select to switch the focus to manual adjustments. Drag the slider below to adjust the focus value.</li> <li>● <b>Auto:</b> Select to switch the focus to automatic adjustment.</li> </ul>
Home Position	Set the camera initial home position when you power it on.	<ul style="list-style-type: none"> <li>● <b>Last Operation Position:</b> Select to switch the initial home position to the last operation position before you power the camera off.</li> <li>● <b>Factory Center Position:</b> Select to switch the initial home position to the factory setting position (facing toward).</li> <li>● <b>Preset 0:</b> Select to switch the initial home position to Preset 0.</li> </ul>
Sleep Position	Set the camera position when it is idle for a certain period (configurable sleep timer) and go to the sleep mode.	<ul style="list-style-type: none"> <li>● <b>Factory Downside Position:</b> Select to switch the sleep position to the factory setting position (facing down).</li> <li>● <b>Preset 9:</b> Select to switch the sleep position to Preset 9.</li> </ul>
Sleep Timer	Set the camera idle time to enter sleep mode. <b>[Notes]</b> The camera won't enter sleep mode during USB Streaming or RTSP/RTMP Streaming.	<ul style="list-style-type: none"> <li>● Off</li> <li>● 10 sec</li> <li>● 5 min</li> <li>● 10 min</li> <li>● 20 min</li> </ul>
On Screen Menu	Enable or disable on-screen status information.	<ul style="list-style-type: none"> <li>● <b>Off:</b> Stop showing all on-screen status info when operating the camera.</li> <li>● <b>On:</b> Show all on-screen status info when operating the camera.</li> <li>● <b>Load Preset Off:</b> Only stop showing the on-screen info when loading presets.</li> </ul>
Camera Binding	Select a camera to operate. Specify a number in the setting to connect.	<ul style="list-style-type: none"> <li>● Off</li> <li>● Camera1</li> <li>● Camera2</li> <li>● Camera3</li> </ul>
Save Preset	Enable or disable this function. When off, you can't save preset points via IR remote, Hot key, VISCA, and webpage.	<ul style="list-style-type: none"> <li>● Off</li> <li>● On</li> </ul>

## Image Settings

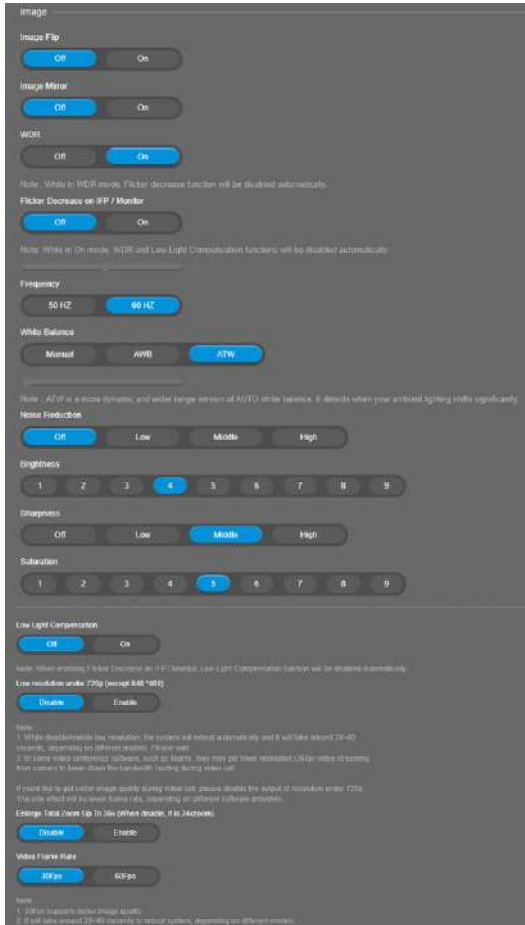

Item	Description	Options
Image Flip	Enable or disable the camera view to rotate 180 degrees vertically.	<ul style="list-style-type: none"> <li>● Off</li> <li>● On</li> </ul>
Image Mirror	Enable or disable the camera view to flip 180 degrees horizontally.	<ul style="list-style-type: none"> <li>● Off</li> <li>● On</li> </ul>

WDR (Wide Dynamic Range)	Enable or disable to improve image quality and visibility in low light environments. <b>[Notes]</b> When <b>WDR</b> mode is on, <b>Flicker Decrease</b> function will be disabled.	<ul style="list-style-type: none"> <li>● Off</li> <li>● On</li> </ul>
Flicker Decrease on IFP / Monitor	Enable or disable to decrease flickers when focusing the camera on digital monitors.	<ul style="list-style-type: none"> <li>● Off</li> <li>● On</li> </ul>
Frequency	Select the frequency of the daylight lamp.	<ul style="list-style-type: none"> <li>● 50 HZ</li> <li>● 60 HZ</li> </ul>
White Balance	Select the white balance adjustment.	<ul style="list-style-type: none"> <li>● <b>Manual:</b> Drag the slide bar below to adjust the camera white balance value.</li> <li>● <b>AWB:</b> Select to switch the white balance adjustment to Auto White Balance.</li> <li>● <b>ATW:</b> Select to switch the white balance adjustment to Advance True Wide mode to provide a full range color temperature adjustment.</li> </ul>
Noise Reduction	Select the level of removing noise from signals.	<ul style="list-style-type: none"> <li>● Off</li> <li>● Low</li> <li>● Middle</li> <li>● High</li> </ul>
Brightness	Select the camera brightness level.	<ul style="list-style-type: none"> <li>● Level 1~9</li> </ul>
Sharpness	Select the camera sharpness level.	<ul style="list-style-type: none"> <li>● Off</li> <li>● Low</li> <li>● Middle</li> <li>● High</li> </ul>
Saturation	Select the camera saturation level.	<ul style="list-style-type: none"> <li>● Level 1~9</li> </ul>
Low Light Compensation	Enable or disable auto light adjustment.	<ul style="list-style-type: none"> <li>● Off</li> <li>● On</li> </ul>
Low resolution under 720p (except 848*480)	Enable or disable low resolution, and the system will reboot automatically (around 20~60 seconds).	<ul style="list-style-type: none"> <li>● Disable</li> <li>● Enable</li> </ul>

---

Enlarge Total

Zoom Up To 36x  
(When disable, it  
is 24xzoom)

Select to switch the zoom  
rate.

- Disable
  - Enable
- 

Video Frame  
Rate

Switch the video frame  
rate of the camera. When  
the setting changes, the  
camera will reboot (around  
20~60 seconds).

- 30Fps
  - 60Fps
-

## RS-232 Settings

When **VC520 Pro3** connects with PTZ camera controller through the RS-232 port, set up the following settings.

Item	Description
ADDR	Select the camera ADDR port from <b>1</b> to <b>8</b> .
Baud Rate	Select the camera baud rate: <ul style="list-style-type: none"><li>● 2400</li><li>● 4800</li><li>● 9600</li><li>● 115200</li></ul>
Protocol	Select the camera protocol: <ul style="list-style-type: none"><li>● VISCA</li><li>● Pelco-P</li><li>● Pelco-D</li></ul>
VISCA Over IP	Turn on or off the setting.

# Video Format Settings

You can configure the video format settings, RTSP and RTMP settings.

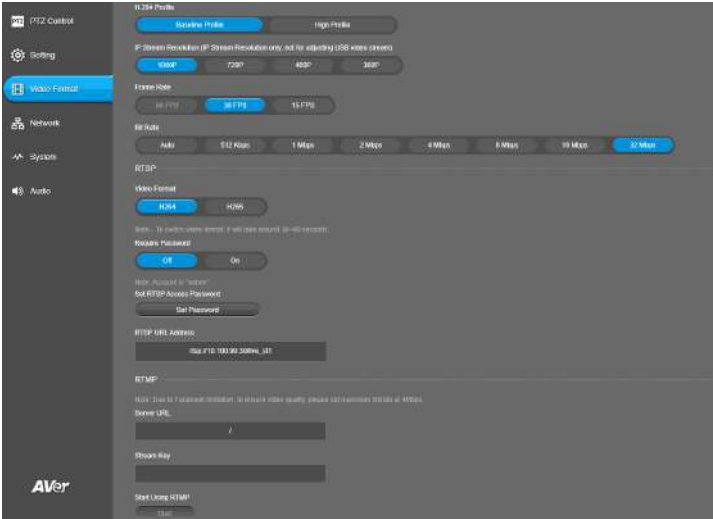

Item	Description
H.264 Profile	Select a camera profile for the best streaming quality: <ul style="list-style-type: none"><li>● Baseline Profile</li><li>● High Profile</li></ul>
IP Stream Resolution	Select a resolution for IP stream (not supported for USB video stream): <ul style="list-style-type: none"><li>● 1080P</li><li>● 720P</li><li>● 480P</li><li>● 360P</li></ul> <b>[Notes]</b> If USB streaming (VC software side) is already in use at 1080p/30fps, the IP streaming resolution (RTSP) will be limited to 720p/30fps.
Frame Rate	Select a camera frame rate: <ul style="list-style-type: none"><li>● 60 FPS</li><li>● 30 FPS</li><li>● 15 FPS.</li></ul>
Bit Rate	Select a camera bit rate: <ul style="list-style-type: none"><li>● Auto</li><li>● 512 Kbps</li><li>● 1 Mbps</li><li>● 2 Mbps</li></ul>

- 
- 4 Mbps
  - 8 Mbps
  - 16 Mbps
  - 32 Mbps.
-



## RTSP

### Connect the camera with RTSP player:

1. Copy the RTSP URL in which displays on the application webpage (e.g., VLC, PotPlayer or Quick Time), and paste it into **RTSP URL Address** box.
2. Select video format between **H264** and **H265**. The switch of video format will take around 30~60 seconds.
3. Select **On/Off** in **Require Password** section to enable/disable password requirement while opening RTSP.

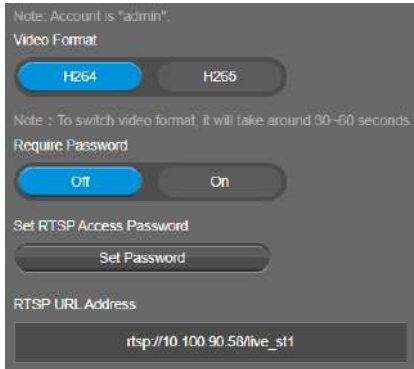

### Set and Change RTSP Password:

1. Go to **Video Format > RTSP > Set RTSP Access Password > Set Password**.
2. Enter a new password.
3. Select **Change** to save the new password.

## RTMP

To upload the camera's live view to the broadcasting platform (e.g. YouTube):

1. Go to **Video Format > RTMP**.
2. Copy the RTMP server URL and stream key from the broadcasting platform, and paste it in **Server URL** and **Stream Key** fields.
3. Select **Start** to begin uploading the camera live stream to the broadcasting platform.
4. Select **Stop** to stop uploading the live video.

Note: Due to Facebook limitation, to ensure video quality, please set maximum Bitrate at 4Mbps.

Server URL

Stream Key

Start Using RTMP

# Network Settings

You can configure hostname, IP address, Gateway and more.

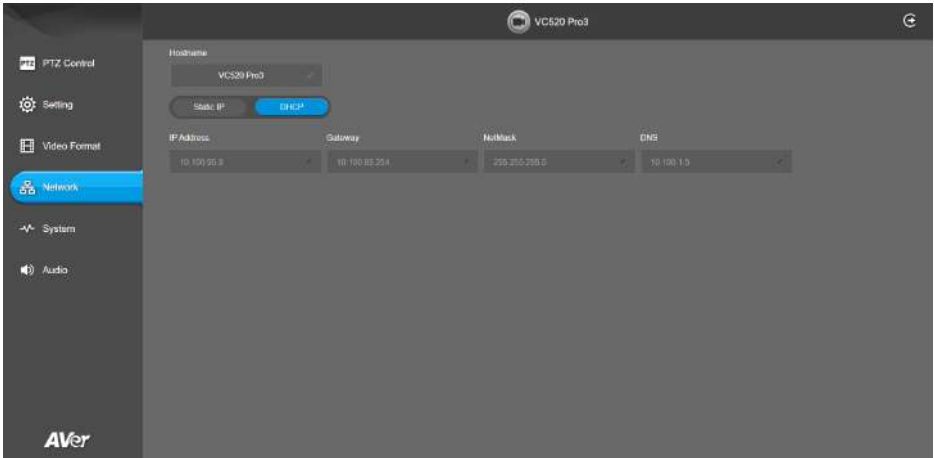

Item	Description
Hostname	Click the pencil icon to enter a hostname (numeric and alphabetic characters only).
Static IP	Click to edit and assign a fixed IP address to the camera. Click the pencil icon to edit: <ul style="list-style-type: none"><li>● IP Address</li><li>● Gateway</li><li>● NetMask</li><li>● DNS</li></ul> When finished, click <b>Confirm</b> .
DHCP	Click to enable Dynamic Host Configuration Protocol. The IP Address, Gateway, Netmask and DNS will can't be edited.

# System Settings

You can configure system language, FW Update setting, set back to Factory Default and more.

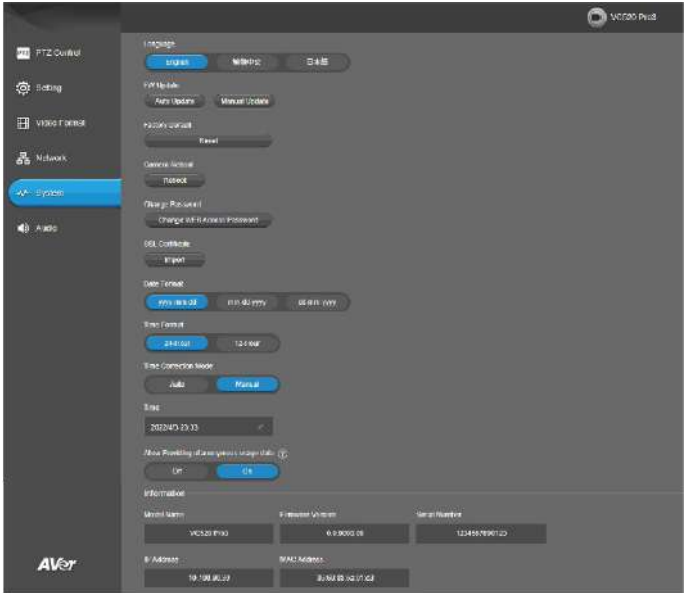

Item	Description
Language	Select the system language among <b>English</b> , <b>Traditional Chinese</b> and <b>Japanese</b> .
FW Update	Select a firmware update method for your camera: <ul style="list-style-type: none"><li>● Auto Update</li><li>● Manual Update</li></ul>
Factory Default	Click <b>Reset</b> to reset the camera system settings.
Camera Reboot	Click <b>Reboot</b> to restart the camera.
Change Password	Click <b>Change WEB Access Password</b> to enter the old username and password and enter the new username and password to reset.
SSL Certificate	Click <b>Import</b> to upload certificate file from your computer.
Date Format	Select the date format to be displayed as: <ul style="list-style-type: none"><li>● yyyy-mm-dd</li><li>● mm-dd-yyyy</li><li>● dd-mm-yyyy</li></ul>

---

Time Format	Select the displayed time format: <ul style="list-style-type: none"><li>● 24-Hour</li><li>● 12-Hour</li></ul>
Time Correction Mode	Select a time correction mode: <ul style="list-style-type: none"><li>● <b>Auto:</b> You can edit NTP(Network Time Protocol) Server and select a Time Zone.</li><li>● <b>Manual:</b> You can edit and enter date and time. When finished, click <b>Confirm</b>.</li></ul>
Allow Providing of anonymous usage data	Enable this function to help AVer continuously improve our products and services. Please visit AVer's privacy policy for more information: <a href="https://www.aver.com/privacy">https://www.aver.com/privacy</a>
Information	Display the camera information including: <ul style="list-style-type: none"><li>● Model Name</li><li>● Firmware Version</li><li>● Serial Number</li><li>● IP Address</li><li>● MAC Address</li></ul>

---

# Audio Settings

You can configure audio settings including noise suppression, automatically gain control, echo cancellation and more.

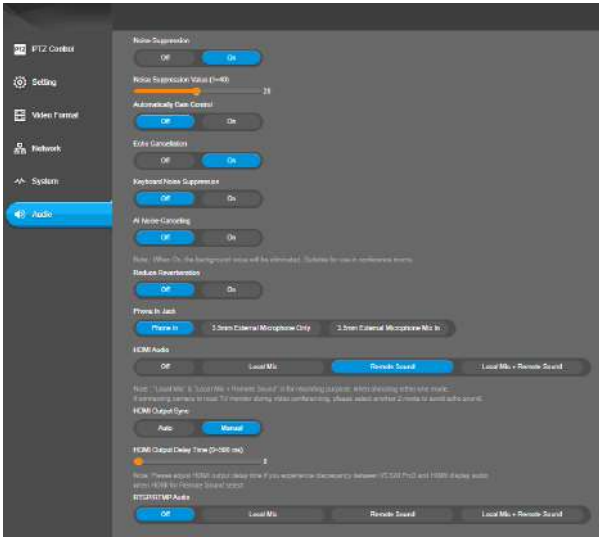

Item	Description
Noise Suppression	Enable or disable the background noise reducing function. Drag the slider below to adjust the value (1~40).
Automatically Gain Control	Enable or disable the system to adjust or maintain a suitable volume output despite a various input.
Echo Cancellation	Enable or disable the echo elimination.
Keyboard Noise Suppression	Enable or disable the keyboard noise reduction.
AI Noise-Cancelling	Enable or disable the background noise elimination (e.g. crying babies or barking dogs).
Reduce Reverberation	Enable or disable the indoor sound reverberation reduction.
Phone in Jack	<ul style="list-style-type: none"> <li>● <b>Phone In:</b> To involve participants joining a meeting via smartphone, connect it to the VC520 Pro3 Speakerphone with a 3.5mm cable.</li> <li>● <b>3.5mm External Microphone Only:</b> To use your external microphone as the only audio input source, connect it to the VC520 Pro3 Speakerphone with the microphone's 3.5 mm cable.</li> <li>● <b>3.5mm External Microphone Mix In:</b> To use your external microphone and VC520 Pro3 Speakerphone at the same time, connect it to the VC520 Pro3 Speakerphone with the</li> </ul>

---

	microphone's 3.5 mm cable.
HDMI Audio	<p>When connected to HDMI, set your audio source from:</p> <ul style="list-style-type: none"><li>● Off</li><li>● Local Mic</li><li>● Remote Sound</li><li>● Local Mic + Remote Sound</li></ul>
HDMI Output Sync	<p>This function is only available when <b>HDMI Audio &gt; Remote Sound Only</b> is selected.</p> <p>Select a mode for the <b>HDMI Output Sync</b>:</p> <ul style="list-style-type: none"><li>● <b>Auto</b></li><li>● <b>Manual</b>: Drag the slider below the adjust the HDMI Output Delay Time (0~500 ms)</li></ul>
RTSP/RTMP Audio	<p>When connected to RTSP/RTMP, set your Audio source from:</p> <ul style="list-style-type: none"><li>● Off</li><li>● Local Mic</li><li>● Remote Sound</li><li>● Local Mic + Remote Sound</li></ul>

---

# EZLive

EZLive is a software program that allows you to record videos from the camera or your PC screen, and upload live streaming to the streaming platforms. Please go to <https://www.aver.com/Downloads/search?q=EZLive> to download the AVer EZLive software. After downloading, double-click on the file and follow the on-screen instructions to complete the installation.

## Introduction

During a video call, you can use EZLive to:

- (1) Camera ePTZ
- (2) Volume control for the speaker connected
- (3) Capture camera's still images
- (4) Record video
- (5) Live stream to YouTube, Livehouse.in, USTREAM...etc.
- (6) Camera Zoom in/out
- (7) Capture PC screen shot
- (8) Record PC screen video
- (9) Set up livestream
- (10) Open file management to retrieve photos and video files
- (11) Livestream setting
- (12) Drawing tool

